

# Boliden Summary Report

Resources and Reserves | 2020

## Kankberg – Åkulla Östra

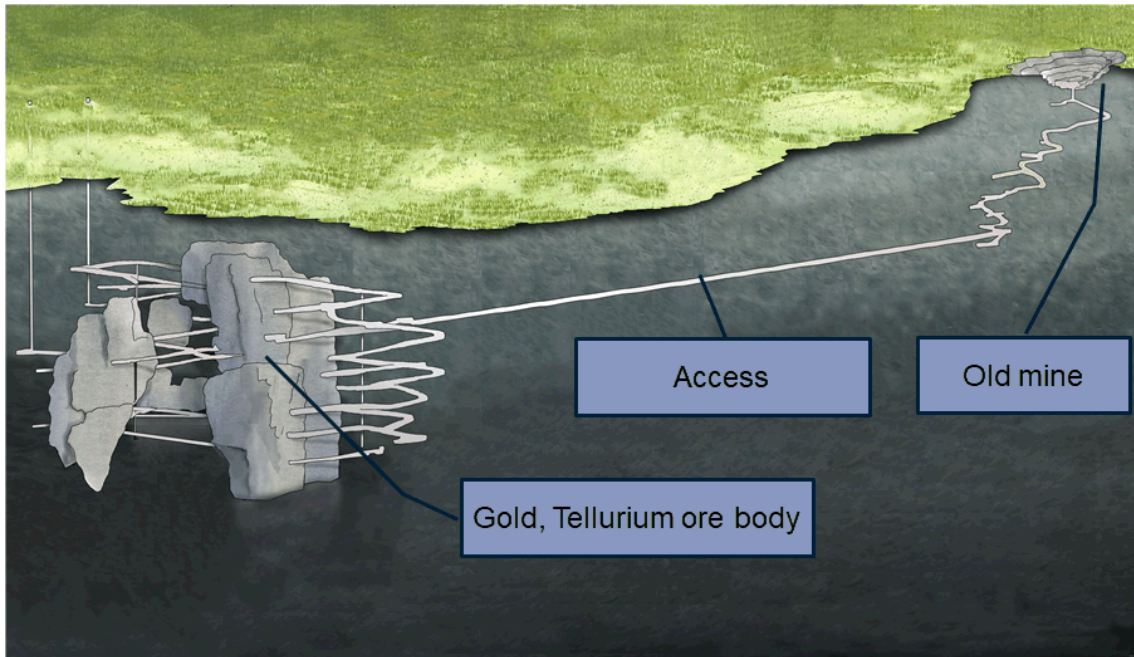

---

Prepared by  
Birger Voigt and Johan Bradley

# Table of contents

1	Summary	6
2	Competence	7
3	ASSESSMENT CRITERIA	7
3.1	Purpose of Report	8
3.2	Project Outline	8
3.3	History	10
3.4	Key Plan, Maps and Diagrams	15
3.5	Project Location and Description	16
3.6	Topography and Climate	18
3.7	Geology	18
3.8	Mineralogy	22
3.9	Mineral rights and land ownership	22
3.10	Legal Aspects and Tenure	23
3.11	Licenses and permits	24
3.12	Personal introduction into projects and verification of the data	24
3.13	Type(s) of sampling	25
3.14	Drilling techniques	25
3.15	Drill sample recovery	25
3.16	Logging	26
3.17	Other sampling techniques	27
3.18	Sub-sampling techniques and sample preparation	27
3.19	Assay data and laboratory investigation	27
3.20	Verification of results	30
3.21	Data location	31
3.22	Data density and distribution	32
3.23	Reporting Archives	32
3.24	Audits or reviews	32
3.25	Database integrity	32
3.26	Geological interpretation	33
3.27	Estimation and modelling techniques	34
3.28	Metal equivalents or other combined representation of multiple components	39
3.29	Cut-off grades or parameters	39
3.30	Tonnage Factor/In-situ Bulk Density	40
3.31	Mining factors or assumptions	40
3.32	Metallurgical factors or assumptions	42
3.33	Mineral Resource estimate for conversion to Mineral Reserves	43
3.34	Cost and revenue factors.	45
3.35	Market assessment.	45
3.36	Others	46
3.37	Classification	46

<b>3.38</b>	<b>Audits or reviews</b>	<b>47</b>
<b>3.39</b>	<b>Discussion of relative accuracy/ confidence</b>	<b>47</b>
<b>3.40</b>	<b>Schematic description of the principles for reporting of Mineral Resource and Mineral Reserve</b>	<b>48</b>
<b>4</b>	<b>Competent Person's Consent Statements</b>	<b>50</b>
<b>5</b>	<b>References</b>	<b>52</b>
<b>5.1</b>	<b>External references</b>	<b>52</b>
<b>5.2</b>	<b>Internal references</b>	<b>52</b>

# List of Figures

Figure 1: Schematic representation of the location of the Boliden Area Operations in Sweden, showing mines, process plant and smelter location. ....	9
Figure 2: Sketch map of a 2 km x 2.5 km area showing the Kankberg orebody outline and access, historic open pits, land rights and coordinate systems. ....	10
Figure 3: Comparison of annual mine and mill contained gold .....	12
Figure 4: Comparison of quarterly mine and mill contained gold .....	12
Figure 5: Comparison of annual mine and mill gold grade.....	13
Figure 6: Comparison of quarterly mine and mill gold grade.....	14
Figure 7: Comparison of annual mine and mill ore tonnes .....	14
Figure 8: Comparison of quarterly mine and mill ore tonnes.....	14
Figure 9: Index Map of the “Kankberg - Boliden” area.....	16
Figure 10: Map of the Kankberg Mining District showing Topography with Mining Concession and Exploration Permits .....	17
Figure 11: Tonnage-frequency distribution and volcanic setting of the 52 known massive sulphide deposits of 0.1 Mt or more in the Skellefte district (modified from Allen et al (1996)). .....	19
Figure 12: Geological map of the Skellefte district. (modified after Kathol & Weihed, 2005) .....	20
Figure 13: Schematic illustration plan of zones FW1, FW2, M1, M2, M4 and infrastructure with north to left.....	21
Figure 14: Schematic illustration of zones FW1, FW2, M1, M2, M4 and infrastructure looking towards north. ....	21
Figure 15: Photographs taken underground of ore fragments; (a) & (b) topaz-altered breccia, (c) & (d) topaz-altered volcanics with andalusite veins, illuminated by (a) & (c) torchlight and (b) & (d) SWUV. ....	22
Figure 16: High-grade gold intersections, which are typical boxes of Kankberg mineralised core. Hole ID, box number and from-to depths are shown.....	26
Figure 17: Graph of results for a gold assay standard, from submitting in batches from 2012 to 2016. ....	30
Figure 18: Probability Graph of Te, Ag and Au Length-Weighted Grades from the entire database of drill sample assays (Nov 2019). ....	31
Figure 19: Grade shells created in Leapfrog based on Au ppm values. ....	34
Figure 20: Length (m) vs gold grade (g/t) in composites .....	36
Figure 21: Au Validation Trend Plot showing 6m north-south sections. Red line represents capped composite mean grades and black line represents block grades. ....	38
Figure 22: (Left) Sketch profile showing stope access. (Right) Illustration of the mining cycle. ....	41
Figure 23: Simplified overview of the different stages of Kankberg ore processing at BAOPP. ....	42
Figure 24: Schematic description of the principles for reporting of Mineral Resource and Mineral Reserve at Kankberg .....	48

## List of Tables

Table 1. Mineral Reserves and additional Mineral Resources from the Kankberg Mine 31-12-2020 and comparison against previously reported on 31-12-2019.....	7
Table 2. Contributors and responsible Competent Persons .....	7
Table 3: Mineral Resources and Ore Reserves at FS, total production and comparison between statements reported 31-12-2019 and 31-12-2020 (Au only).....	11
Table 4: Summary of reconciliation data between 2012 and 2020 (all data).....	13
Table 5: Summary of reconciliation data between 2015 and 2020 (all data).....	13
Table 6: Mining concessions at Kankberg held by Boliden Mineral AB.....	23
Table 7: Exploration permits held by Boliden Mineral AB in the nearby area of the Kankberg Mine.....	23
Table 8. Overview of ALS’s designation of analytical methods.....	28
Table 9. Periodic Table, highlighted to show assayed elements.....	29
Table 10: Number of drill holes and number of assays per element in the Kankberg database supporting the current estimate .....	33
Table 11: Block Model Parameters .....	33
Table 12: Initial length weighted and domain statistics. COV greater than 1.5 has been marked red.....	34
Table 13: Summary of top cut values applied.....	35
Table 14: Semi-variogram parameters for all estimated elements.....	36
Table 15: Search ellipsoid parameters .....	37
Table 16: Comparison of block estimates and composites (top-capped). Deviations greater than 10% in red.....	38
Table 17: Long-Term Net Smelter Return Factors and associated information .....	39
Table 18: Cut-off grade & NSR assumptions .....	40
Table 19: Metallurgical Recoveries .....	43
Table 20: Waste rock and dilution per category.....	44
Table 21: Mining, transport and process operating costs .....	45
Table 22. Long-term metal prices and currency exchange rates .....	45

## Appendix

Appendix 1: Brief history

Appendix 2: Explanation of the Mine Local Grid, G1NSYSTEMET

Appendix 3: Examples of Mine Survey Plans, 3 of 8 that were current in late November 2019

Appendix 4: Examples of Plans and Profiles showing drillholes and block model NSR grades.

Appendix 5: 3D view of Mineral Reserves and Mineral Resources classification and existing infrastructure

## 1 SUMMARY

Boliden AB (“Boliden”) is a Swedish mining and smelting company focusing on production of copper, zinc, lead, gold and silver. Boliden operates six mining areas and five smelters in Sweden, Norway, Finland, and Ireland. The company primarily processes zinc, copper, nickel, gold, lead, and silver and is engaged in exploration, mining, smelting, and metals recycling.

This Competent Person’s Report (CPR) concerns Boliden’s wholly owned Kankberg mine (Sweden) and has been prepared in accordance with the guidelines set out in the Pan-European Reserves and Resources Reporting Committee (PERC) “PERC Reporting Standard 2017”. The report is updated and issued annually to provide the public (stakeholders, shareholders, potential investors and their advisers) with:

- A comprehensive overview of the Kankberg mine as an on-going mining operation;
- Mineral Resource and Mineral Reserve statements for the mine and a description of methods used to estimate these; and
- An overview of the Boliden Area Operations, of which the Kankberg mine is a part.

The Kankberg mine is located 41 km northwest of Skellefteå in Västerbotten county, northern Sweden. Production commenced in 2012 and has continued uninterrupted to the present day, for a total of 3.4 million tonnes (Mt), with an average grade of 3.6 g/t Au, 9 g/t Ag and 162 g/t Te. Current production is from underground cut and fill methods, between depths of -530m and -330m level, via a ramp-drive system from the historic Kankberg open pit mine to the north. In 2020, the mine produced 535 618 tonnes at an average grade of 3.43 g/t Au, 9.2 g/t Ag and 157.1 g/t Te, of which 524 909 tonnes was transported to surface for processing.

Approximately 96% of total forecast revenue from Kankberg is derived from gold (Au), with remainder from tellurium (Te) and silver (Ag).

Run of mine ore from Kankberg is stockpiled and trucked to the Boliden Area Operations central concentrator (10 km), before further processing to final product at the Rönnskär smelter (50 km). Kankberg has a forecast mine life to 2031. The mine employs roughly 115 staff and additional contractors.

The effective date of this report is 31 December, 2020.

A summary of Mineral Reserves and additional Mineral Resources is presented in Table 1. The block model used as a basis for estimation of Mineral Resources and Mineral Reserves was prepared in November 2019. This model and supporting data is described in the 2019 CPR for Kankberg. As such, much of the technical discussion in this report is a repeat of the 2019 CPR. Where appropriate, the text, tables and figures have been updated to reflect 2020 production and certain adjustments in operating assumptions. An updated block model for Kankberg was finalized in late November 2020 and will be available as a basis for the next annual report.

Table 1. Mineral Reserves and additional Mineral Resources from the Kankberg Mine 31-12-2020 and comparison against previously reported on 31-12-2019.

Classification	2020					2019				
	kt	Au (g/t)	Ag (g/t)	Te (g/t)	Bi (g/t)	kt	Au (g/t)	Ag (g/t)	Te (g/t)	Bi (g/t)
<b>Mineral Reserves</b>										
Proved	2 610	3.3	11	179	87	3 110	3.3	11	179	87
Probable	1 930	3.5	6	135	80	1 930	3.5	6	135	80
<b>Total</b>	<b>4 530</b>	<b>3.4</b>	<b>9</b>	<b>162</b>	<b>84</b>	<b>5 050</b>	<b>3.4</b>	<b>9</b>	<b>162</b>	<b>84</b>
<b>Mineral Resources</b>										
Measured	200	3.5	8	121	84	200	3.5	8	121	84
Indicated	670	4.0	8	162	100	670	4.0	8	162	100
<b>Total M&amp;I</b>	<b>870</b>	<b>3.9</b>	<b>8</b>	<b>152</b>	<b>97</b>	<b>870</b>	<b>3.9</b>	<b>8</b>	<b>152</b>	<b>97</b>
Inferred	1 460	3.9	7	161	106	1 460	3.9	7	161	106

## 2 COMPETENCE

Information supporting this report includes historic data and recent studies, compiled by a team of Boliden's in-house technical staff. These individuals are specialists in their field and, in general, have extensive personal experience of the operation. Their role in the preparation of this document is presented in Table 2, along with an indication as to responsibility and Competent Person (CP) status.

Table 2. Contributors and responsible Competent Persons

Report Section	Contributors	Support to Competent Persons	Competent Persons
Overall report compilation	Birger Voigt		Johan Bradley
Geology	Birger Voigt, Susanne Holmen	Lina Åberg	Gunnar Agmalm
Resource Estimation	Lina Åberg		Gunnar Agmalm
Reserve Estimation	Tina Zizek	Markus Isaksson	Gunnar Agmalm
Mineral Processing	Lisa Malm		Anders Sand
Mining	Tina Zizek	Markus Isaksson	Gunnar Agmalm
Environmental permitting	Anna Virolainen	Joanna Lindahl	Seth Mueller

See Section 4 for Competent Person professional affiliations and Consent Statements.

## 3 ASSESSMENT CRITERIA

This section of the report is to support the reporting of Mineral Reserves and additional Mineral Resources by providing information prompted by Table 1 in the PERC Standard.

PERC Table 1 has four columns. The first is 'Assessment Criteria' and its entries are used as the sub-section headings in this section, where they are relevant. This includes 'Table 1 Part 1 – General', 'Part 2 - Sampling Techniques and Data' and 'Part 4 - Estimation and Reporting of Mineral Resources and Mineral Reserves'. Omissions are in 'Part 3 – Reporting of Exploration Results' and Part 5 on diamonds.

The other three Table 1 columns are respectively ‘Exploration Results’, ‘Mineral Resources’ and ‘Mineral Reserves’. Given the development status and operating history of the Kankberg mine, the focus of this report is on column four, ‘Mineral Reserves’.

### 3.1 Purpose of Report

This Competent Person’s Report (CPR) concerns Boliden’s wholly owned Kankberg mine (Sweden) and has been prepared in accordance with the guidelines set out in the Pan-European Reserves and Resources Reporting Committee (PERC) “PERC Reporting Standard 2017” (see [www.percstandard.eu](http://www.percstandard.eu)). This is one of the world-wide CRIRSCO (see [www.crirSCO.com](http://www.crirSCO.com)) group of standards, along with JORC, CIM, SAMREC etc.

The report is updated and issued annually to provide the public (stakeholders, shareholders, potential investors and their advisers) with:

- A comprehensive overview of the Kankberg mine as an on-going mining operation;
- Mineral Resource and Mineral Reserve statements for the mine and a description of methods used to estimate these; and
- An overview of the Boliden Area Operations, of which the Kankberg mine is a part.

It is a full evaluation of supporting information for the Mineral Reserves and additional Mineral Resources, at the effective date of 31/12/2020.

This CPR is based on the 2019 CPR (Kankberg – Åkulla Östra Au mine, Boliden Mineral Resources and Reserves Report 2019), which has been updated to reflect 2020 production and changes to certain operating assumptions.

Boliden adopted the current reporting guidelines (PERC) in 2019. The authors acknowledge that work is on-going to address any gaps in supporting information, in order to produce a CPR that is intended, as far as possible, to comply with the PERC Standard and to uphold the main principles governing its operation and application of transparency, materiality, competence, and impartiality.

### 3.2 Project Outline

The Kankberg mine is located 41 km northwest of Skellefteå in Västerbotten county, northern Sweden. Ore is hosted by an alteration zone in a suite of felsic volcanic and volcanoclastic rocks. Production commenced in 2012 and has continued uninterrupted to the present day, for a total of 3.4 million tonnes (Mt), with an average grade of 3.6 g/t Au, 9 g/t Ag and 162 g/t Te (31 Dec, 2020).

Current production is from underground, cut and fill methods, between depths of -530 and -330 level, via a ramp-drive system from the historic Kankberg open pit mine to the north. Room-and-Pillar layout is used, where the ore is taken in rooms of generally 6m in height, and 10m wide leaving pillars of 6m x 6m. When the level is mined out, it is backfilled so that the level above can be mined. Fill is waste rock, either from elsewhere in the mine, or trucked in from the waste dumps at an historic mine.



In 2020, the mine produced 535 618 tonnes at an average grade of 3.43 g/t Au, 9 g/t Ag and 157 g/t Te (reconciliation 2020), of which 524 909 tonnes was transported to surface for processing.

Run Of Mine (ROM, i.e. just mined) ore from Kankberg is stockpiled on surface before being trucked to the Boliden Area Operations Processing Plant (BAOPP), a distance of 10 km from the mine. The ore from Kankberg is processed in campaigns or batches, each of which may take a few weeks. The recovery of gold achieved from Kankberg ore is 86%. Tailings from all three mines are deposited at a tailings management facility close to the BAOPP. At present production levels, both process plant and tailings management facility are considered to have sufficient capacity to see out the life of Kankberg.

Concentrates and doré bars containing gold and silver from the BAOPP are transported about 50 km to Boliden's Rönnskär smelter at the port of Skelleftehamn, from where the refined metals are marketed. Tellurium is sold as a concentrate mainly to China.

BAOPP receives material from two other mines in the area, namely Renström and Kristineberg. A fourth mine, Maurliden, which also used the BAOPP, ceased operations in 2019 due to depletion.



Figure 1: Schematic representation of the location of the Boliden Area Operations in Sweden, showing mines, process plant and smelter location.

A potential risk to the Kankberg Mineral Reserves and Mineral Resources is that future new and more valuable mineral discoveries in the district could replace capacity in the tailings management facility currently earmarked for Kankberg. While negative for the Kankberg operation, this would be a positive risk for the investor.

Another potential risk to the Kankberg operation is that being part of the BAOPP in the event of lack of Mineral Reserves and Resources from one or more of the other operations could Kankberg supply enough ore to sustain the operation of the concentrator.

### 3.3 History

Figure 2 is a sketch map to show the approximate location of the deposit in relation to three historic open pit workings and other features. The map coordinate grid is SWEREF99 TM.

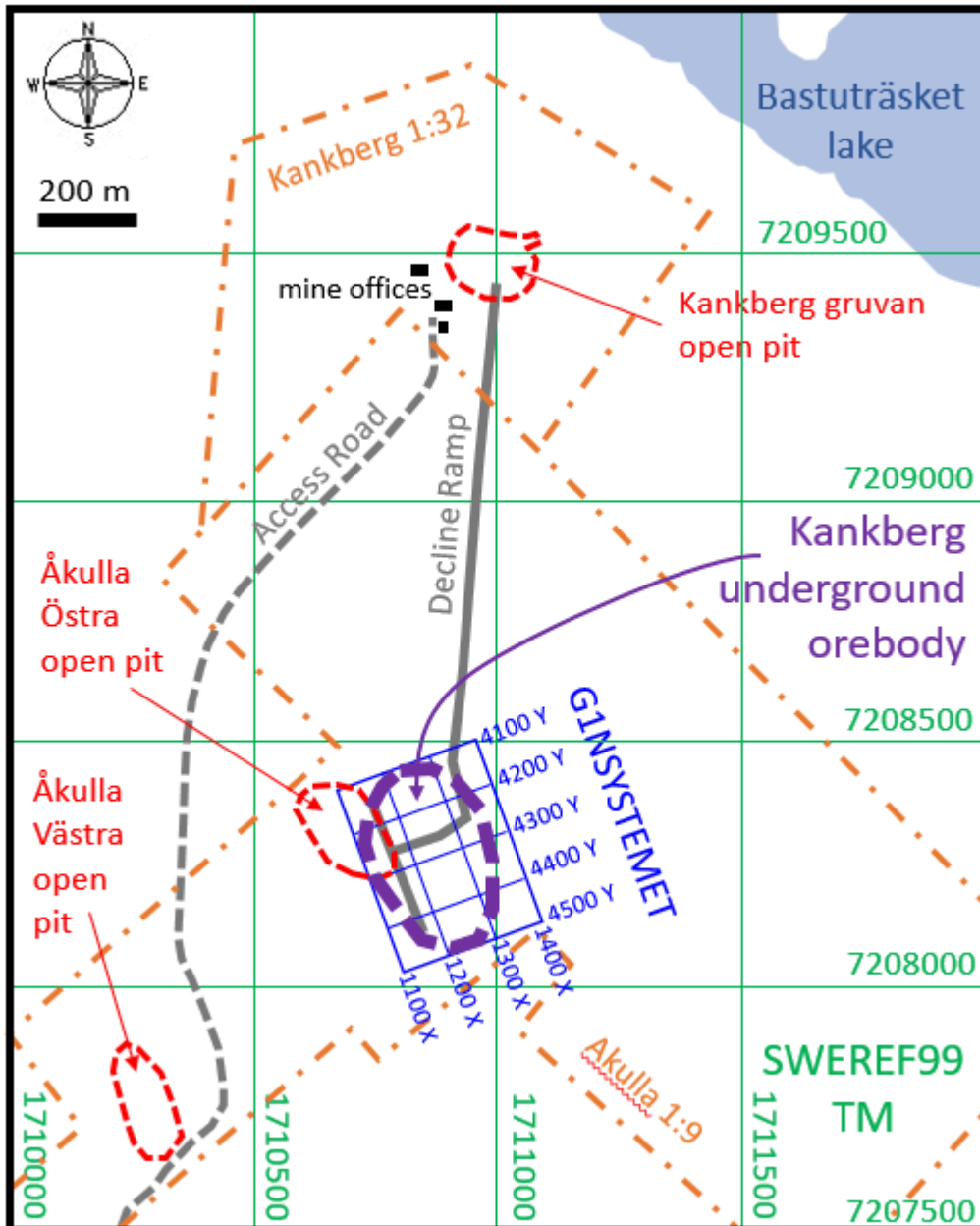

Figure 2: Sketch map of a 2 km x 2.5 km area showing the Kankberg orebody outline and access, historic open pits, land rights and coordinate systems.

The three historic open pits are Åkulla Östra, Åkulla Västra and Kankberg gruvas, which is now also called 'The Old Kankberg Mine'. Sulfide-hosted copper, gold, silver and a little zinc were mined from these deposits. Respectively, their ore tonnages were 197 kt, 967 kt and 1.17 Mt. The former two were mined during 1997 to 1998 and 1947 to 1956 respectively. These open pits have been filled and reclaimed. Kankberg gruvas was mined in two periods, from 1966 to 1969 and 1988 to 1998 and now provides access to the (New) Kankberg Mine,

via a decline ramp from the base of the pit to the underground orebody. The mine offices and stockpiles are near Kankberg gruvan at the end of the tarred access road.

A brief pre-production history of the Kankberg project is given in Appendix 1, up to the Feasibility Study (FS) of January 2011 and production commencing in January 2012. The FS included 117 drill holes comprising 15 415 metres, all assayed in mainly 2 m samples.

A feature of the Mineral Resources reported for Kankberg is that they include factors for mining dilution and recovery, which vary with category (i.e. Inferred to Measured). These are described and discussed below under 'Mining factors or assumptions'. These factors mean that Mineral Resources and Mineral Reserves can be aggregated together for analysis; if not for reporting then at least for reconciliation of what was mined with what was estimated through the history of the mine operation.

For comparative purposes, Table 3 lists the Mineral Resources and Reserves (for Au only) reported respectively in:

- The feasibility study from 31-12-2010;
- Total production to 31-12-2020; and
- The statement from 31-12-2020.

This shows that exploration and infill drilling have increased the contained gold in Mineral Reserves, both mined and to be mined by 144%, or by a factor of 2.4 during the time period 31-12-2010 to 31-12-2019.

Table 3: Mineral Resources and Ore Reserves at FS, total production and comparison between statements reported 31-12-2019 and 31-12-2020 (Au only).

<b>Classification</b>						
	<b>FS, reported 2010-12-31</b>		<b>Total Production</b>		<b>Reported 2020-12-31</b>	
	<b>kt</b>	<b>Au (g/t)</b>	<b>kt</b>	<b>Au (g/t)</b>	<b>kt</b>	<b>Au (g/t)</b>
Proved Reserve	120	3.5	3 400	3,6	2 610	3.3
Probable Reserve	2 661	4.1			1 930	3.5
<i>Total Reserve</i>	<i>2 781</i>	<i>4.07</i>			<i>4 530</i>	<i>3.4</i>
Measured Resource	59	2.2			200	3.5
Indicated Resource	605	2.4			670	4.0
Inferred Resource	120	6.0			1460	3.9

Monthly production figures have been recorded since production started, for both the mine and the mill. The mine figures are calculated using surveyed volumes of what was mined to evaluate tonnes and grades from the most recently estimated block model. These will be of Proved Mineral Reserves, since before ore is mined it has passed through the stages of infill drilling, estimation and planning to reach Proved category.

The mill figures are calculated by weight and sampled grades of comminuted feed after milling. Since there is no grade control sampling to provide independent adjudication, a

comparison between the mine and mill figures would be the best indication of the quality of the block model estimation, and hence of the quality of the Proved Mineral Reserves. Figure 3 and Figure 4 show comparisons of contained gold in mine and mill figures, respectively on an annual and quarterly basis.

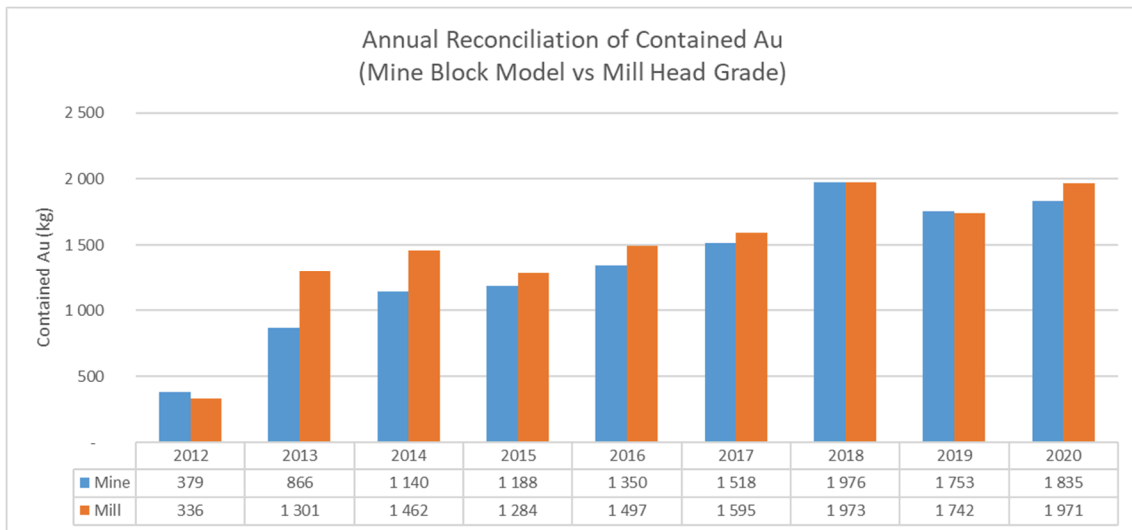

Figure 3: Comparison of annual mine and mill contained gold

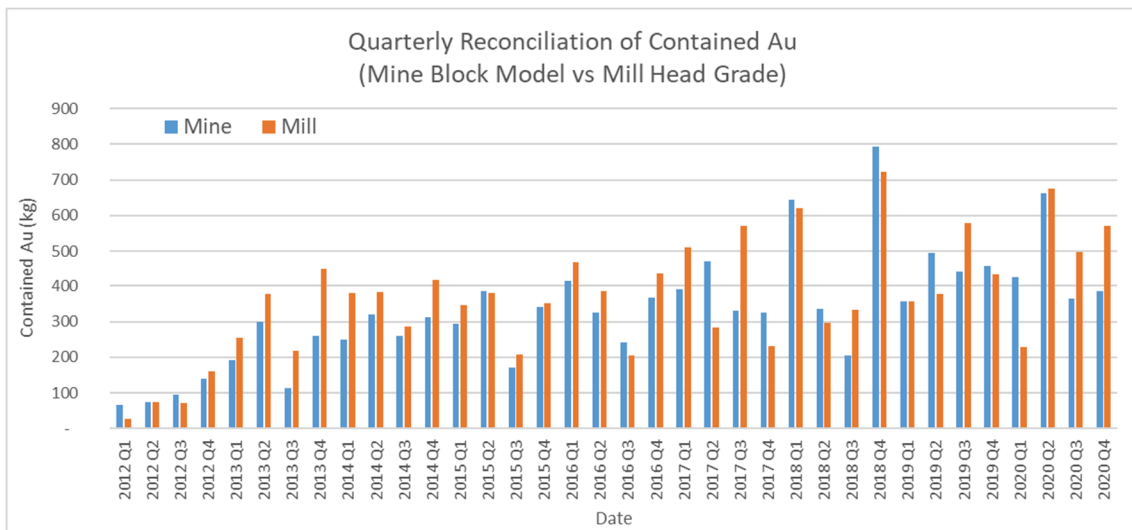

Figure 4: Comparison of quarterly mine and mill contained gold

An important aspect to consider when reviewing these graphs is that ore is mixed through a process of transport and stockpiling, once at the mine, and then again on arrival at the mill. ROM stockpile residence time at the mine typically varies from between 1 to 6 months, but may be as much as 18 to 24 months in smaller sections of the pile. Material residence time at the mill typically varies from between 1 to 3 months prior to batch processing at the BOAPP. As such, there is little value in attempting a monthly reconciliation.

In the quarterly graph, most of the disparity between mine and mill is strongly influenced by this delay. In the annual graph, the effect of stockpiling is less obvious. There appears to be a consistent bias between the years 2013 and 2016, with the mill reporting higher contained gold. Whilst there is an improvement in performance between 2017 to 2020, the latest reconciliation data from 2020, suggests this bias may still exist.

The reconciliation data is summarized in Table 4 and Table 5 below, for the time periods 2012 to 2020 and 2015 to 2020 respectively. The Relative Accuracy figures are at 90% confidence, which means that a result would be expected to fall outside the accuracy range in 10% of cases.

Table 4: Summary of reconciliation data between 2012 and 2020 (all data)

Unit of comparison	Mine	Mill	% Diff	Relative Accuracy	
				Quarterly Basis	Annual Basis
Contained Au (kg)	12 005	13 161	9%	27%	14%
Grade (g/t)	3.49	3.88	10%	20%	14%
Tonnes (Mt)	3 443	3 395	1%	28%	14%

Table 5: Summary of reconciliation data between 2015 and 2020 (all data)

Unit of comparison	Mine	Mill	% Diff	Relative Accuracy	
				Quarterly Basis	Annual Basis
Contained Au (kg)	9 620	10 063	4%	23%	5%
Grade (g/t)	3.60	3.71	6%	13%	7%
Tonnes (Mt)	2 671	2 621	-2%	21%	4%

For all data shown above, the total contained gold for the mine was 12 005 kg and the total for the mill was 13 161 kg, giving a difference of 9%. Estimation techniques in earlier years were not at the standard that is now applied and there has been gradual improvement. The FS model was calculated using the Inverse Power of Distance estimation calculation rather than the more accurate Kriging. Kriging was introduced early 2012 when the drill density was considered sufficient to support geostatistical variogram study. Since January 2015, the total contained gold for the mine was 9 620 kg and the total for the mill was 10 063 kg, giving a difference of 4%, which is a marked improvement.

To further investigate, Figure 5 and Figure 6 show comparisons of gold grade in mine and mill figures, respectively annual and quarterly. Figure 7 and Figure 8 show comparisons of ore tonnes in mine and mill figures, respectively annual and quarterly.

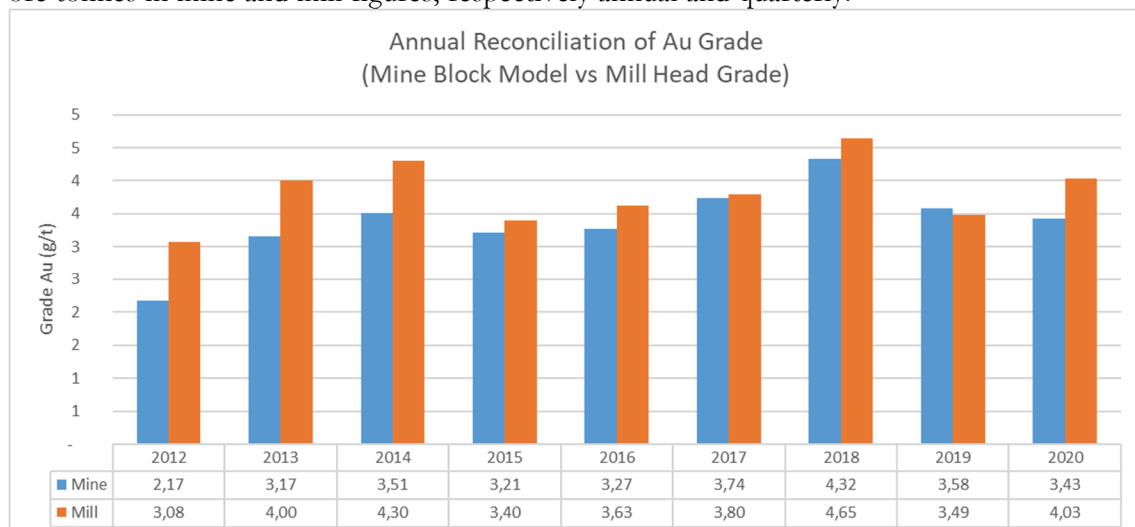

Figure 5: Comparison of annual mine and mill gold grade

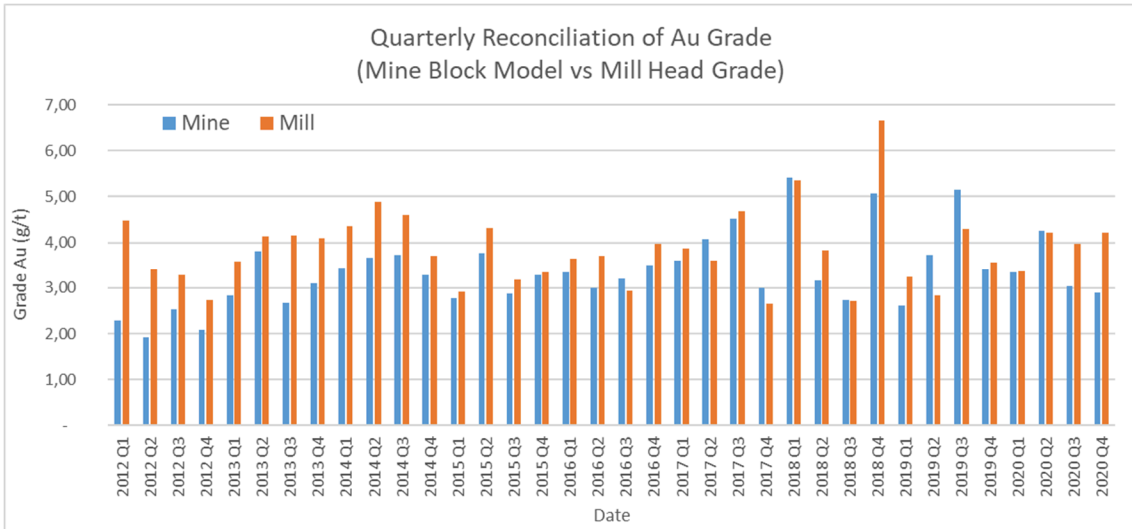

Figure 6: Comparison of quarterly mine and mill gold grade

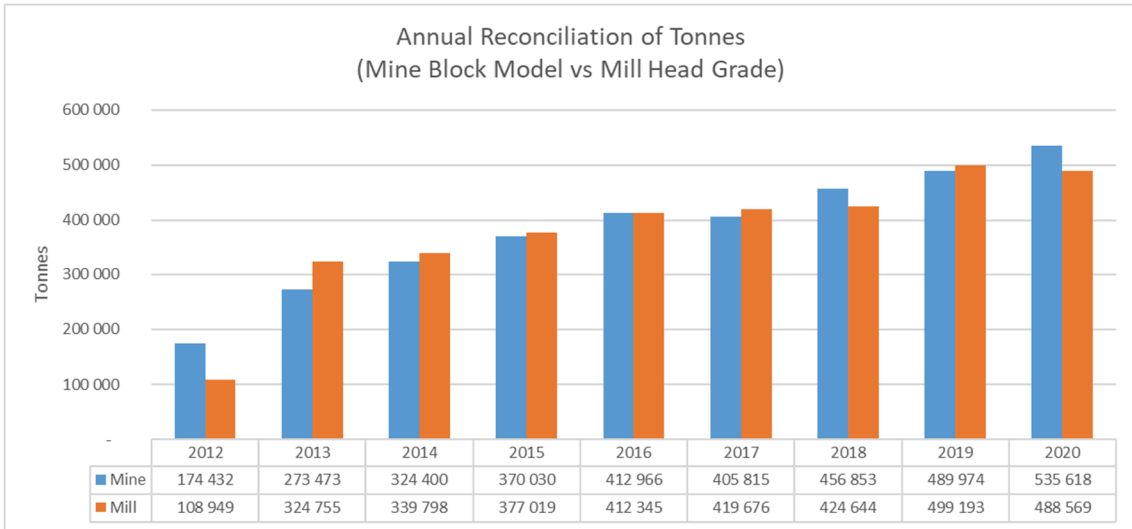

Figure 7: Comparison of annual mine and mill ore tonnes

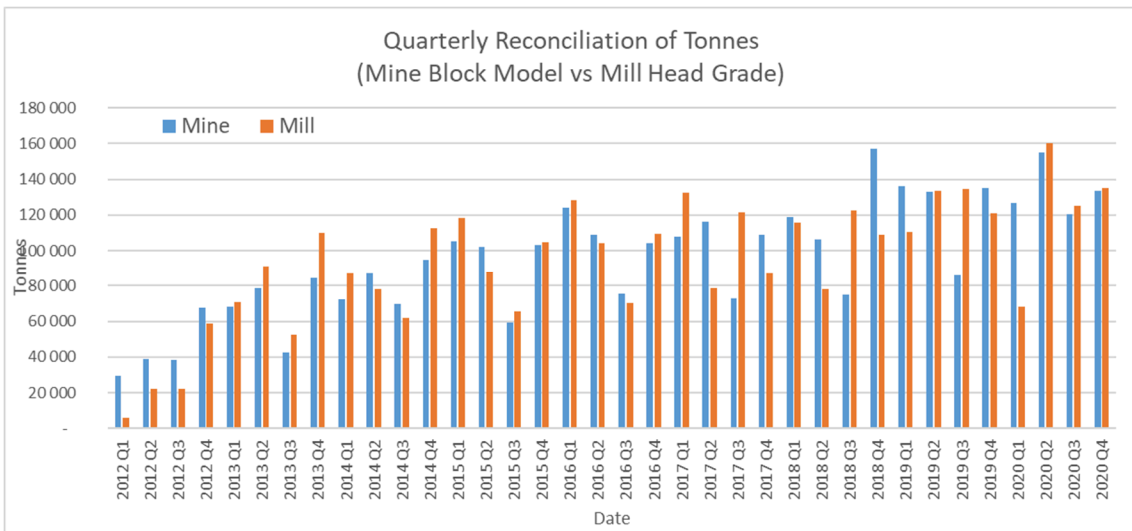

Figure 8: Comparison of quarterly mine and mill ore tonnes

In each case, these four graphs show reasonable correspondence, if allowance is made for the delay in processing described above. There is much greater correspondence in the annual figures due to smoothing of the disparities seen in the quarterly figures.

For all time periods, there was a total of 3.44 Mt of ore for the mine and the total for the mill was 3.39 Mt, giving a difference of 1%. Since January 2015, there were 2.67 Mt for the mine and the total for the mill was 2.62 Mt. It appears that the estimation of tonnage is unbiased. One might ask if the same comparison can be completed for grade. But since grade should be weighted by tonnes, this calculation is essentially the same as that carried out for contained gold as described above (see Table 4 and Table 5 above).

There is a specific reason for selecting annual and quarterly time periods for reconciliation. In an important presentation, the Chairman of CRIRSCO and an authority on mineral asset estimation and reporting, Dr Harry Parker (2010) proposed that “Indicated Mineral Resources should be known with a relative accuracy of  $\pm 15\%$  at 90% confidence for annual production increments” and that “Measured Mineral Resources should be known with a relative accuracy of  $\pm 15\%$  at 90% confidence for quarterly production increments”. The reference to “known” is generally in terms of contained product. These proposals are for a ‘typical’ deposit. It has been considered that for a near-marginal iron ore deposit, a relative accuracy of better than  $\pm 10\%$  rather than  $\pm 15\%$  may be appropriate, whereas for a nuggetty mineral such as gold, a relative accuracy of  $\pm 20\%$  may be more appropriate and may still be difficult to achieve.

To investigate the Proved category, which has been transferred from Measured Mineral Resources by planning, the relative accuracy for quarterly production increments must be determined. Assuming that the error is equally distributed between the mine and the mill, and for all the contained gold figures from 2012 Q1, a Coefficient of Variation (CoV) was determined between mine and mill data of 0.1661. Using the inverse of the Normal Distribution, this gives a relative accuracy of  $\pm 27\%$  at 90% confidence (Table 4). However, from the graphs, statistics and discussion above, estimation for the early years was probably unreliable relative to the present.

From 2015 Q1 the CoV is 0.1393, which gives a relative accuracy of  $\pm 23\%$  at 90% confidence (Table 5). This still may be considered poor, but not in the context of the delay in processing through the effects of stockpiling, which on the quarterly basis must cause most of the disparity between mine and mill. If the effect of this delay could be removed from the mill figures, then it seems likely that the relative accuracy at 90% confidence would be well within  $\pm 20\%$  and possibly better than  $\pm 15\%$ .

**Therefore, it is concluded that the drilling density and estimation at the Measured and Proved categories yield results that are both unbiased and of adequate accuracy.**

### 3.4 Key Plan, Maps and Diagrams

Figure 9 shows a road and topography map of the Kankberg - Boliden area. The coordinate system used here is the Svenska Rikssystemet RT 90 2.5 gon väst, and is the older national standard, but is similar to the present national cadastral standard SWEREF99 TM. The location of the ‘New’ i.e. present Kankberg Mine is shown as a blue mine symbol, while the ‘Old’ Kankberg Mine, which provides access, is shown as an exhausted (upside-down) mine symbol. Ore from the mine is transported 10 km southeast to the Boliden Area Operations Processing Plant (BAOPP), shown as a blue square near the small town of Boliden.

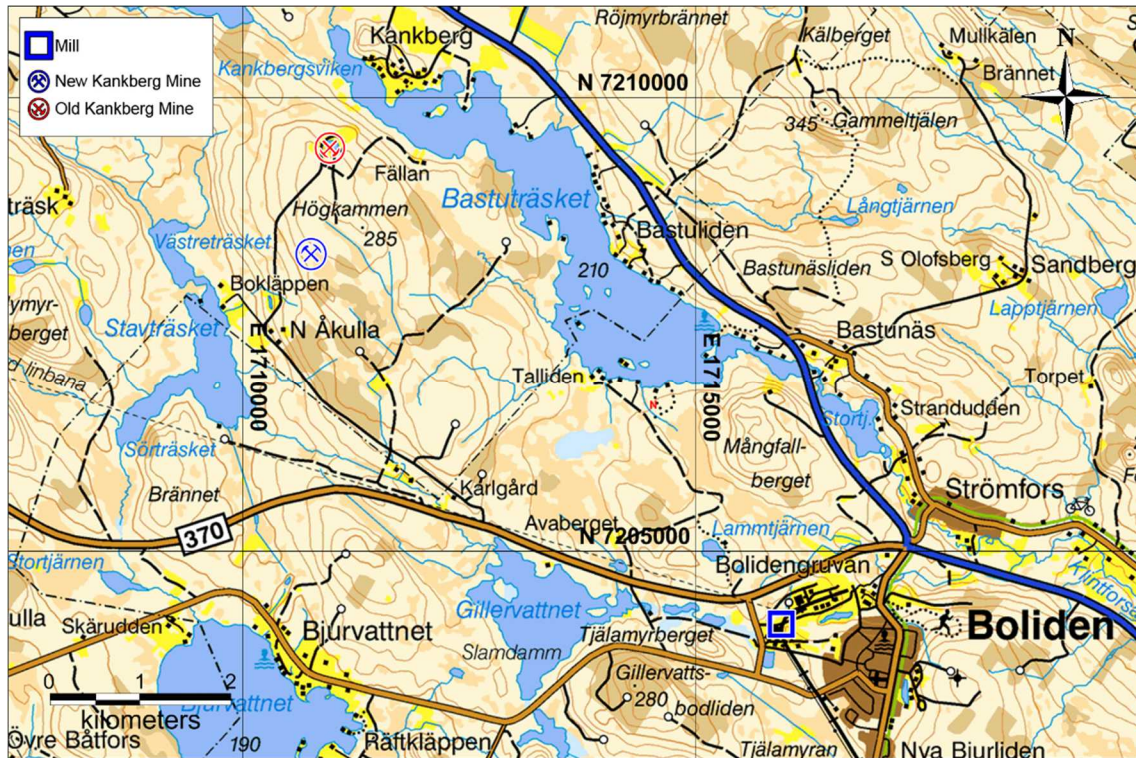

Figure 9: Index Map of the “Kankberg - Boliden” area

### 3.5 Project Location and Description

The Kankberg mine is located at latitude 64°55'20" N longitude 20°16'00" E in the north of Sweden, the province and county of Västerbotten and in the Skellefteå Municipality, close to its border with the neighbouring Norsjö Municipality. It lies about 41 km northwest of the city of Skellefteå with hotels, airport connections to Stockholm, and its port, Skelleftehamn, on the Gulf of Bothnia.

Figure 10 below is a map that gives locations of mining and exploration concessions in the Kankberg district, with further details under ‘Mineral rights and land ownership’ and ‘Legal Aspects and Tenure’, below. The coordinate grid used for the map is the present national cadastral standard SWEREF99 TM. Within the mining concessions there are a few houses, now owned by Boliden and maintained but unoccupied.



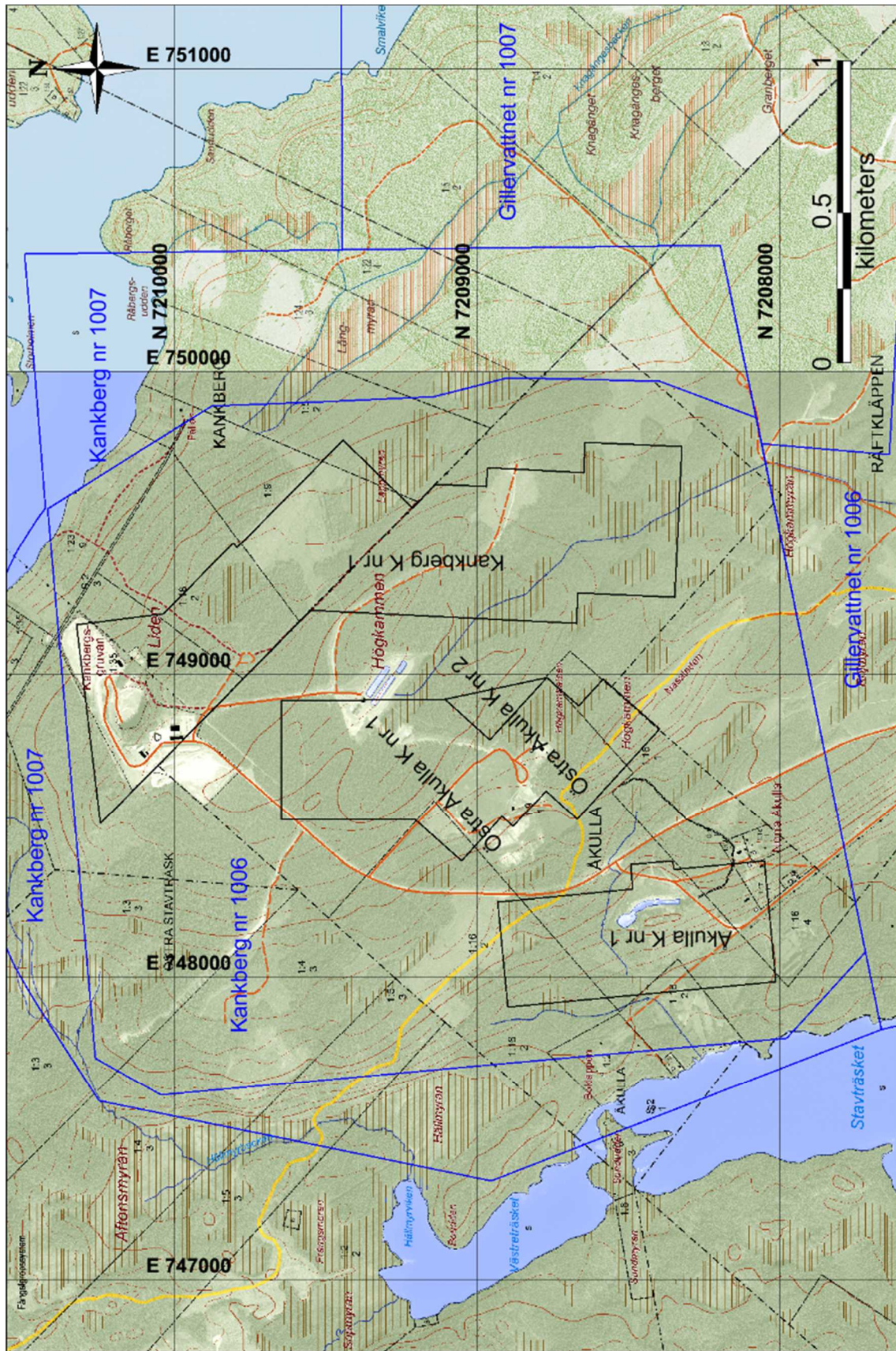

Figure 10: Map of the Kankberg Mining District showing Topography with Mining Concession and Exploration Permits

Boliden have an on-going program of exploration in the district. There is an occurrence of sulfides being investigated by underground drilling from a location by the decline ramp, but there are no exploration sites in the locality that can be shown on a map.

Most mine surveying, all data location and internal plans at Kankberg use the Kankberg Mine coordinate system G1NSYSTEMET. Part of this grid is illustrated in blue in the map above. Plans using the G1NSYSTEMET have 'north' at the top of the page which is rotated 74.215° from the grid north of the national cadastral standard SWEREF99 TM. Please refer to Appendix 2 for a document explaining the relationship between G1NSYSTEMET and national grid systems.

### 3.6 Topography and Climate

Figure 10 above is a topo-cadastral map of the 4.5 km x 3 km district around the mine to show the topography with mining and exploration concessions held by Boliden.

The topography is flat to undulating with low hills and lakes, consistent with a terrain glaciated during the ice ages. A hill called Högkammen, 285 m, is in the mine area and is one of the highest in the district. The water level of nearby lakes is around 200 m. Most of the mine area is forested, and apart from mining, forestry is the main land use in the district.

The area is sparsely populated and nearest significant settlement is the village of Kankberg, situated about 1 km to the northeast, across the Kankbergsviken embayment of the Bastuträsket lake.

The climate is cold temperate. For Skellefteå the temperature averages 1.9 °C, with month average lows in January and February of -12 °C and a high of 21 °C in July. The high rainfall has an annual average of about 560 mm with significant rainfall in all months. Each day there are 4 hours of daylight in December and 21 hours in June. The underground operation has little influence from the climate, except for de-watering, which is higher during the annual Spring melt. Ventilation air may be heated and the temperature underground in the mine is 8 to 10 °C.

### 3.7 Geology

The Kankberg Mine lies within the eastern part of the Skellefte mining field, one of the most important mining regions in Sweden, where Boliden has been active since the 1920s. It's significance in relation to 52 other known deposits in the field is shown in Figure 11 from a paper by Allen et al (1996) that describes the marine volcanic arc setting of these Zn-Cu-Au-Ag polymetallic massive sulfide deposits, vein Au deposits and porphyry Cu-Au-Mo deposits.

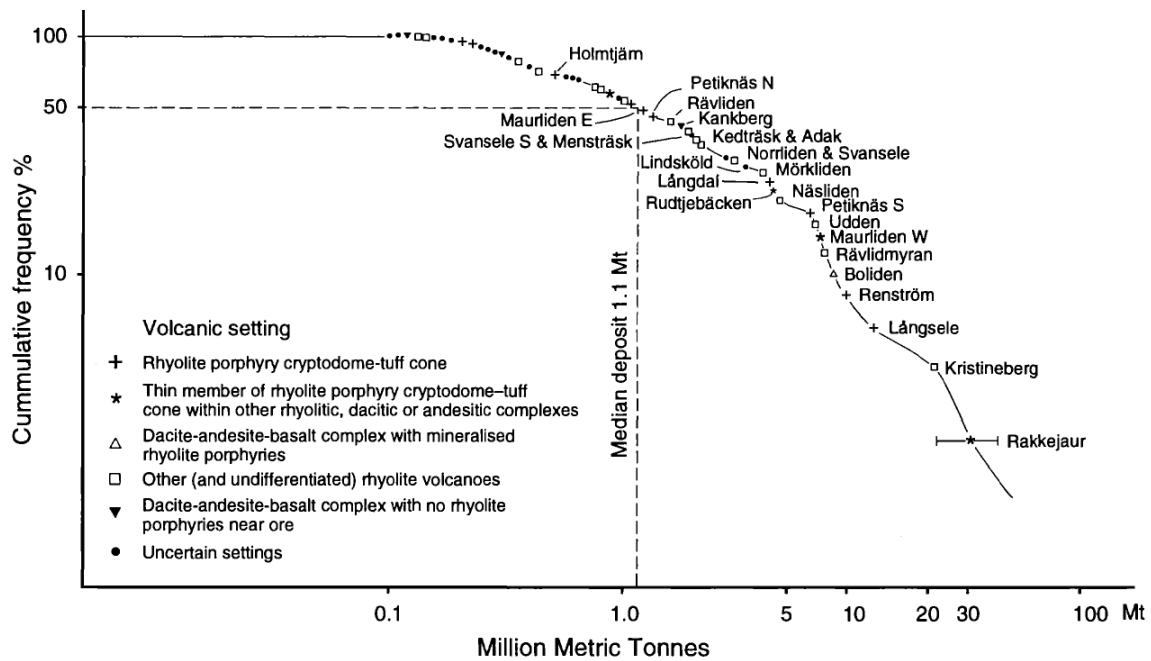

Figure 11: Tonnage-frequency distribution and volcanic setting of the 52 known massive sulphide deposits of 0.1 Mt or more in the Skellefte district (modified from Allen et al (1996)).

The majority of known ore deposits in the Skellefte field occur within the upper parts of the Skellefte group, which is a regionally dominant sequence of volcanic rocks that were formed during a period of intense, extensional, continental margin arc volcanism about 1.89 Ga ago. This group is shown on the geological map in Figure 12, with Kankberg shown at the lower-right. The inset on the left shows the location in relation to Scandinavia.

The host rock in the Kankberg area is dominated by volcanic rocks of primarily dacitic and rhyolitic compositions forming quartz-feldspar porphyritic, rhyolitic and dacitic rock types. The felsic magmas forming these volcanics intruded as shallow (subvolcanic) dykes and sills and extruded as lavas at the surface where they mixed with sediments and mass flows derived from volcanic slopes. The volcanism initiated a convection of solutions through the rocks. These solutions dissolved and transported minerals and metals to sites of deposition.

After the major volcanic period had ended the area was subsequently deformed and folded. This resulted in a dominantly vertical trend of the rocks and structures. At a later stage, brittle deformation took place. Fractures and fissures were intruded by mafic magma forming basaltic and andesitic dykes, which are common in the Kankberg area.

The Kankberg gold deposit is hosted in a complex mix of volcanic rocks consisting primarily of quartz-feldspar porphyry, volcanoclastics and breccias. The host rocks are strongly altered by silicification, andalusite ± topaz alteration and to a varying degree sericitization. The strong alteration form a highly competent body, which is surrounded by dacites. The contact zone is characterized by sericite ± chlorite alteration associated with pyrite ± pyrrhotite.

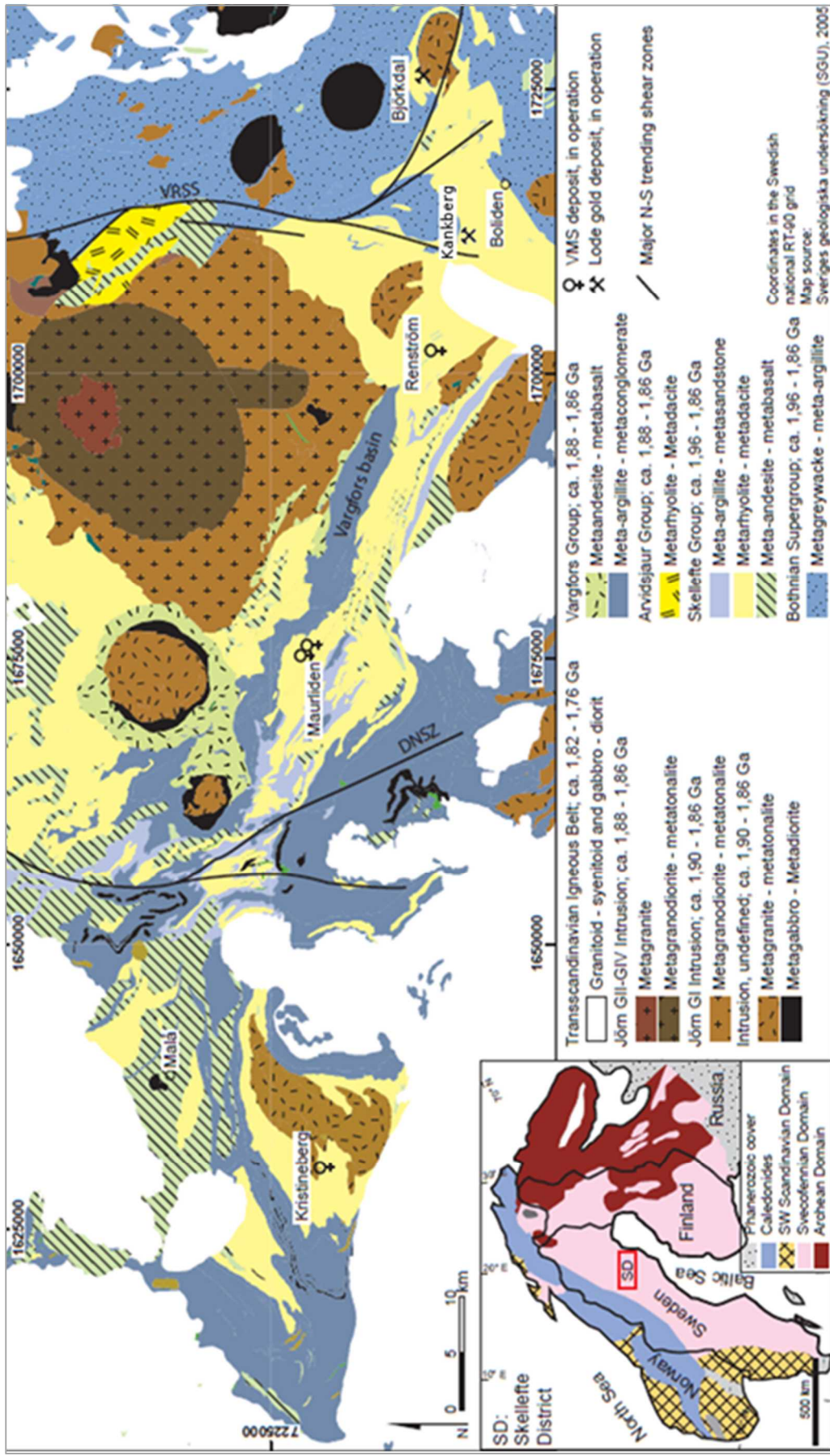

Figure 12. Geological map of the Skellefte district. (modified after Kathol & Weihed, 2005)

For mine planning, the gold mineralization is divided into 5 zones known as FW1, FW2, M1, M2 and M4 as shown below. These aggregate higher-grade lenses are spatially separated by lower-grade rock and may not have genetic significance.

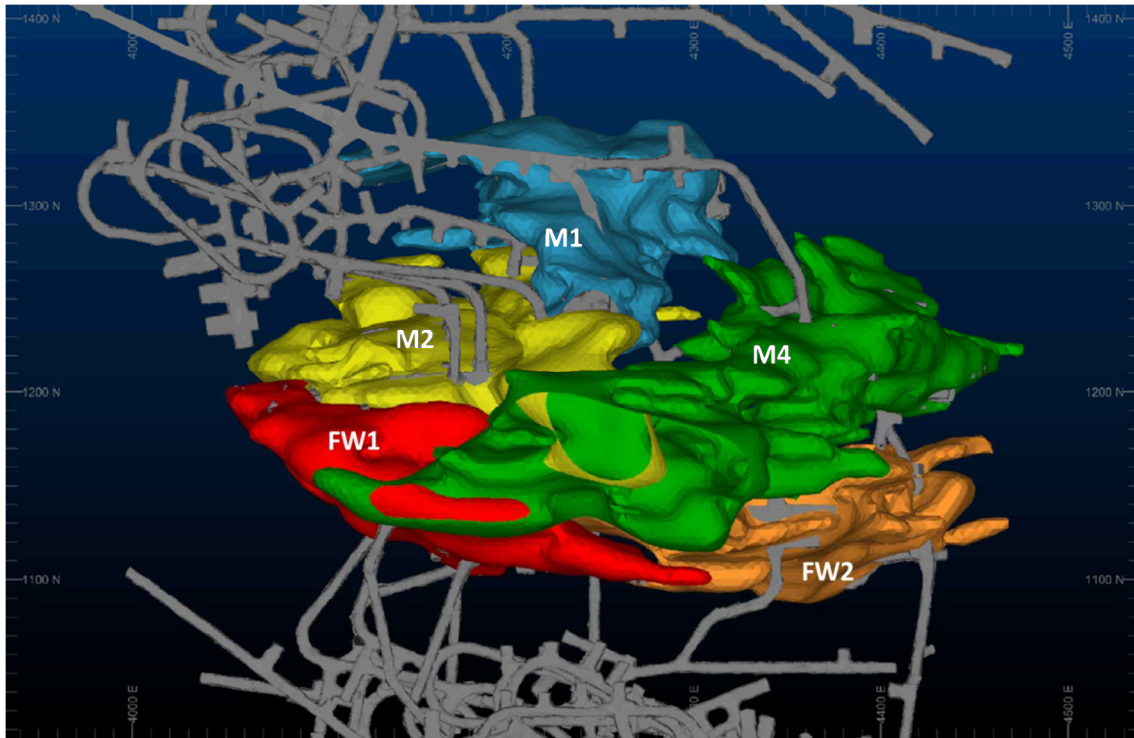

Figure 13: Schematic illustration plan of zones FW1, FW2, M1, M2, M4 and infrastructure with north to left.

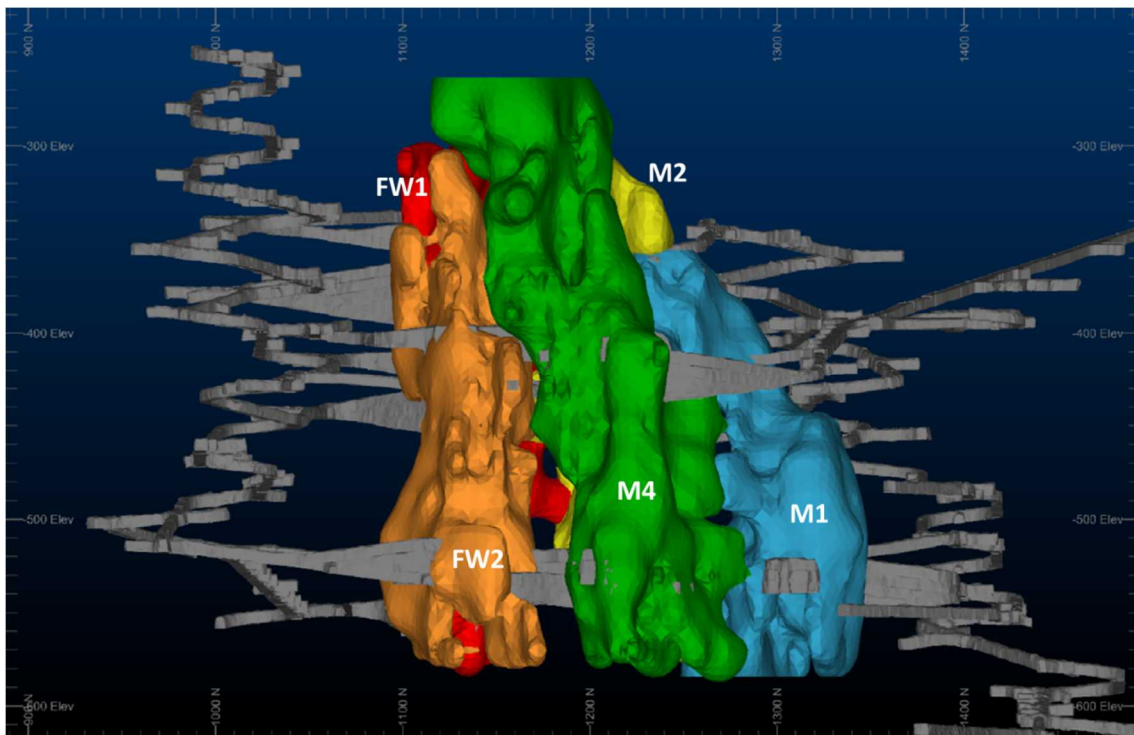

Figure 14: Schematic illustration of zones FW1, FW2, M1, M2, M4 and infrastructure looking towards north.

### 3.8 Mineralogy

The economic mineralization is contained in ‘metallic’ minerals primarily located within the quartz-andalusite ± topaz alteration. It includes fine-grained native gold alloyed with silver at proportions of between 0 to 20%. More commonly, gold occurs as gold-tellurides including petzite ( $\text{Ag}_3\text{AuTe}_2$ ), calaverite ( $\text{AuTe}_2$ ) and sylvanite ( $\text{AuAgTe}_4$ ). Another common telluride is tellurobismuthite ( $\text{Bi}_2\text{Te}_3$ ). Several more telluride minerals have been identified through microscopy. A mineral list is given in <https://www.mindat.org/loc-18583.html>.

Sulfides, pyrite with less pyrrhotite, sphalerite and chalcopyrite, are of minor significance but generally increase upwards through the deposit. Through the process route described later, the metallic minerals are reasonably easily separated from the silicate minerals, which generally cause no issues. A minor exception is talc, which can impair flotation by floating with the metallics, but can be of more concern as an occasional cause of poor geotechnical conditions. It is noted with muscovite in core logging. Otherwise, for processing, it has not been considered necessary to further investigate the variability of the mineral species within the alteration envelope, other than what is indicated by grade distributions.

It is worth saying that the topaz and andalusite are far from being of gem quality. They are frequently seen underground as milky bluish-grey patches and fine-grained cream-coloured vein infillings, respectively. But the topaz has itself undergone alteration and the whole rock mass has strong pervasive silicification. The introduction of andalusite seems to be at least partly a later phase, occurring in veins that cut topaz patches. Both these minerals fluoresce under Short-Wave Ultra-Violet (SWUV) light, as shown in Figure 15.

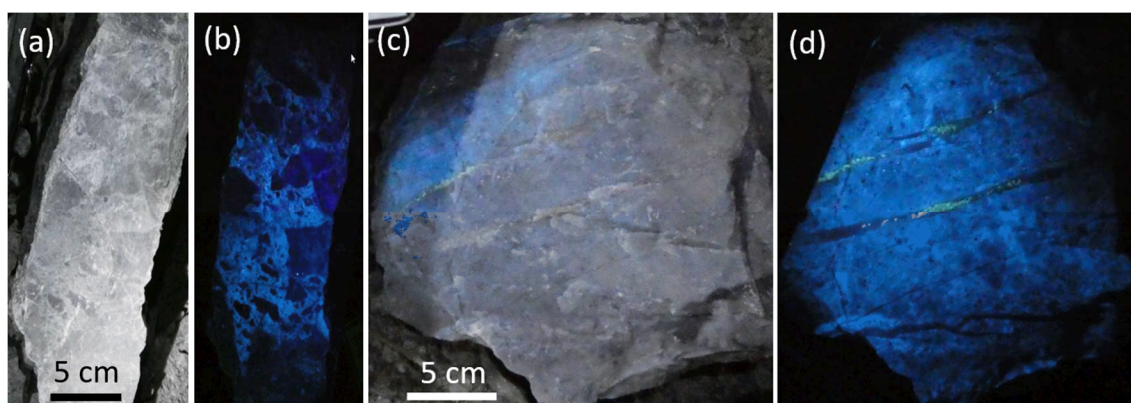

Figure 15: Photographs taken underground of ore fragments; (a) & (b) topaz-altered breccia, (c) & (d) topaz-altered volcanics with andalusite veins, illuminated by (a) & (c) torchlight and (b) & (d) SWUV.

Lens examination of hand-specimens may show, in addition to features above, tourmaline needles and throughout the rock a sparse scattering of tiny (<0.2 mm) dark particles which appear to be metallic minerals. Some are rusted and probably include pyrite/pyrrhotite.

### 3.9 Mineral rights and land ownership

The four mining concessions whose locations are shown in Figure 10 are all 100% owned by Boliden Mineral AB and entitle the extraction of gold, silver, zinc, copper and lead. In Sweden, tellurium is classified as an industrial mineral (as for example, is limestone) and not a concession mineral and is not therefore required to be specified in the mining concession. Such minerals may be exploited, providing the operator owns the land and has a valid environmental permit. Further details of these concessions are given in Table 6.

Table 6: Mining concessions at Kankberg held by Boliden Mineral AB

Name	Diary No.	Area (ha)	Valid from	Valid to
Östra Åkulla nr 1	2000000066:R	45.1598	2001-02-05	2026-02-05
Östra Åkulla nr 2	2009000945	2.8158	2009-11-10	2034-11-10
Kankberg K nr 1	1998000694:R	95.384	2000-01-01	2025-01-01
Åkulla K nr 1	2000000064:R	33.7698	2001-02-05	2026-02-05

In addition, four exploration permits whose locations are shown in Figure 10 are all 100% owned by Boliden Mineral AB and allow exploration for metals as listed in Table 7: Exploration permits held by Boliden Mineral AB in the nearby area of the Kankberg Mine.

Table 7: Exploration permits held by Boliden Mineral AB in the nearby area of the Kankberg Mine

Name	Diary No.	Area (ha)	Mineral	Valid from	Valid to
Kankberg nr 1006	2017000666	358.20	Au, Cu	2017-11-07	2020-11-07
Kankberg nr 1007	2018000745	222.62	Au, Cu, Zn	2018-11-14	2021-11-14
Gillervattnet nr 1007	2016000088	293.83	Au	2016-04-14	2022-04-14
Gillervattnet nr 1006	2016000067	266.73	Au	2016-03-10	2022-03-10

Boliden owns the land and has full surface rights surrounding and immediately adjacent to the mine. The main relevant plots are Kankberg 1:35 and Åkulla 1:9, whose outlines are shown on Figure 10. Reference to these can be found at the following URL:

- <https://www.hitta.se/kartan!~64.92183,20.26536,14.890010460154181z/trli=1QQ6Z6Xq/tileLayer!l=1/realestate!a=1l=64.92271:20.26837?&search=kankberg&sst=plc&st=weblis>
- <https://www.hitta.se/kartan!~64.90115,20.24821,12.623905594365325z/trli=1QQ6Z6Xq/tileLayer!l=1/realestate!a=1l=64.91993:20.26318?&search=kankberg&sst=plc&st=weblis> .

Boliden also owns surrounding plots.

### 3.10 Legal Aspects and Tenure

Boliden Mineral AB is in possession of all required permits to mine Au, Ag, Te, Cu, Zn, Pb at the Kankberg Mine, as listed above, and the necessary land use designation from the Mining Inspectorate. Mining concessions and exploration permits are issued by the Mining Inspectorate of Sweden (Bergsstaten) which is part of the Geological Survey of Sweden (SGU). Details may be found on the website at <https://www.sgu.se/en/mining-inspectorate/> . The Inspectorate is headed by the Chief Mining Inspector who decides on matters falling under the Mineral Act (1991:45), issued on the 24<sup>th</sup> January 1991, which came into force on the 1<sup>st</sup> July 1992.

There are no known legal proceedings or impediments that may affect Boliden's ability or right to mine at Kankberg. Mining and mining related activities undertaken by Boliden in the district have in general, broad support from the local population, supported by on-going stakeholder engagement as an integral part of Boliden's business processes.

Since Boliden owns all relevant surface and mineral and mining rights, it pays no landowner royalties related to production from Kankberg mine. Notwithstanding this, an annual royalty of 0.05% is payable to the State, based on contained metal in ROM ore and average commodity price over the year.

The capacity and licensing of the existing tailings management facility at BOAPP is sufficient to include material from the existing base case life of mine plan for all the mines operated by Boliden in the Boliden area. This includes tailings from the Kankberg mine.

The mine lies near but outside the northeast boundary of a water protection area for the Skellefteå river valley. This area is classified as a tertiary level protection zone, which has the lowest level of protection, with no specific protection criteria. It should be noted that the entire existing tailings management facility at BOAPP lies within this tertiary zone, with no specified constraints. Therefore, it is considered that this water protection area does not present a risk. There are no other joint ventures, partnerships, historical or cultural sites, wilderness, national park or environmental settings in the vicinity that could present risk to the Kankberg operation.

It is considered that the tenure held by Boliden over the Kankberg Mine, related processing and tailings storage facilities have a high level of security and low-level risk with respect to legal aspects.

### **3.11 Licenses and permits**

Details and location plans for mining and exploration concessions and also land ownership are given in earlier sub-sections.

In accordance with the Environmental Law, a main permit as a partial decision: 2011-04-06, mål (case) nr. M739-09 was issued in April 2011 and updated in 2015 with final conditions for discharges as: 2015-01-23, mål (case) nr. M 739-09. These permits cover matters including:

- Maximum production rate 500 ktpa, with a temporary increase of to 525kt\*, during 2020 (ref: 2020.4192);
- Maximum total concentrations of elements in discharged water (there is no limitation on quantity);
- Maximum noise levels;
- Dust;
- Requirement to run operations as stated in the technical description;
- Acquisition and importation of additional waste rock and/or tailings sand, also temporary storage, for use as fill underground;
- Environmental monitoring;
- Explosives – spillage etc.;
- Remediation plans, to be submitted at least 1 year before closure; and
- As of 2019-11-27 a new financial bank guarantee of 19,2 MSEK was approved by the Environmental Court in case nr M2723-17. The guarantee shall cover all environmental liabilities in case of bankruptcy.

*\* refers to run of mine tonnes transported to surface for processing. Reconciliation data presented in Section 3.3 includes material in temporary stockpiles at the mine and may include some data from the first week of January 2021.*

### **3.12 Personal introduction into projects and verification of the data**

Information supporting this report includes historic data and recent studies, compiled by a team of Boliden's in-house technical staff. These individuals are specialists in their field and have extensive personal experience of the operation and related permitting issues. Their role



in the preparation of this document is presented in Table 2, along with an indication as to responsibility and Competent Person (CP) status.

An independent review was carried out in 2019 by Mr. Mark Howson (BSc ARSM MIMMM CEng FGS, Director and Consultant Mining Geologist with Mineral Resources Professional Limited), who visited the Kankberg Mine and the offices of Boliden Mineral AB (see 2019 CPR).

### **3.13 Type(s) of sampling**

The present orebody has no surface expression and has been explored entirely by drilling, at first from the surface but predominantly by underground drilling as described below. There is no other sampling of in-situ rock.

### **3.14 Drilling techniques**

Exploration and infill drilling are carried out by wireline double-tube diamond core drilling. At present, this is entirely from underground using three rigs equipped with the Wireline 56 system that produces 39 mm diameter core. The Near Mine Exploration Department (UGN) contract the drilling company Protek AB to carry out exploration drilling using a Diamec U6 drill rig. Additionally, the Kankberg Mine (G1N) carries out infill drilling using two drill rigs, a Diamec U6 and a Diamec S6.

Holes older than 1995 are not used for present estimation and are described in the database as 'legacy' holes. Exploration holes have continued to be drilled after the FS until the present. They comprise about a quarter to a third of all the holes, the majority being infill holes. Older holes for the Åkulla Östra were drilled from the surface, as were early FS holes, but most FS holes and all holes since 2011 were drilled from underground and mainly from locations in the mine. To ensure the representative nature of the samples these allow the sub-vertical orebody to be intersected from the side, with holes with dip angles from +45° to -45°. While a wireline is used to retrieve the core barrel, due to the near horizontal holes, a 'fish' is pumped along the rods by drilling fluid pressure to grab the core barrel to retrieve the core at the end of a run. No special measures other than good drilling practice and equipment have been needed to maximize core recovery.

To avoid a need for unnecessary or excessive de-watering, all holes drilled for the FS were plugged with concrete. Plastic plugs with an expanding sealant are now used for all holes.

### **3.15 Drill sample recovery**

With such consistently good ground conditions, core recovery is of the order of 99.5% for all holes. It is very unusual to have recovery of less than 100%, as seen in core boxes in Figure 16. Therefore, it is not considered necessary to record sample recoveries or to consider whether a relationship exists between sample recovery and grade or quality and sample bias.



Figure 16: High-grade gold intersections, which are typical boxes of Kankberg mineralised core. Hole ID, box number and from-to depths are shown.

### 3.16 Logging

Drill core is logged at Boliden Mineral AB's core logging facilities in Boliden. Logging data is captured in WellCAD™ software and data is uploaded to an acQuire™ database.

The following fields are logged:

- Rock type acronym. There are 57 standardized rock types, of which the following 14 are most frequent: quartz-feldspar-porphyry, volcanoclastic, sericite-quartzite, sericite-schist, chlorite-quartzite, dacite, andesite, andalusite-quartzite, topaz fragment rock, breccia, basalt (outside mineralization) and clastic sedimentary.
- Alteration types – andalusite, topaz, sericite, chlorite, silicic
- Mineral proportions of talc and muscovite on a scale of 1 to 5 these affect rock stability and, but of less concern, flotation.
- Other minerals – garnet, tourmaline, sphalerite, galena, chalcopyrite, arsenopyrite, pyrrhotite, pyrite, gold.
- Sulfosalts – tellurides
- Rock Mechanics structures – gouge, diskings, crushed drill core – on a 1 to 5 scale: rare, moderate, common, abundant, pervasive.
- Comments. May include small amounts of e.g. gouge, where too small for above logging.
- The start and ends of samples are assigned and length is adjusted to fit with lithological contacts. Length of samples are aimed at 2 m and usually vary between 0.5 and 2 m. Locally, typically where alteration is weak, the length of samples can approach 3 m.

All core is photographed and the photos are available on-line to Boliden staff. Figure 16 represents core box photographs from two drill holes, selected on the basis that these had the highest gold assay grades in the database. Apart from the fact that they both exhibit strong silicification, the photos show no visual evidence of high grade.

It is considered that the samples have been logged to a level of detail to support appropriate Mineral Resource estimation.

### **3.17 Other sampling techniques**

Apart from by drilling, there are no other samples routinely taken of in-situ rock.

### **3.18 Sub-sampling techniques and sample preparation**

Selection of samples from drilling for assaying is as follows. Exploration holes are generally sampled (and assayed) to about 65% for their length. Infill drill-holes are generally drilled from drill 'cubes' on either side of, and outside the alteration that characterises the ore envelope. The start of the hole is generally not sampled. When the logging geologist identifies alteration that indicates proximity to the ore envelope, sampling starts two core boxes up-hole from the contact. It will continue until the end of the hole, even if it seems that the drill hole has emerged from the other side of the ore envelope into unmineralized rock.

Exploration holes are sampled as half-cores, where core is split length-ways by diamond saw and one half is sent for assaying. The other half is stored for reference. From infill drilling, of those intersections that are sampled, the whole core is submitted as samples. Un-sampled core is stored for a year, after which it is discarded.

Primary samples and QAQC samples (inserted as described below), are bagged and sent by contracted courier service to the ALS geochemistry laboratory in the town of Piteå, about 100 km to the north, where sample preparation – drying, crushing and pulverising - is carried out using procedure PREP – 22. Coarse rejects and sample pulps are stored at the laboratory for a period of three months.

Because the gold and other economic mineralization is so fine grained, the excellent core recovery and drill spacing of 10m x 10m, it is considered that the sampling is representative of the in-situ material collected.

Regarding sample integrity, while the mine and all activity areas including logging have active security, no special measures are considered necessary to protect the integrity of the samples. Visible gold is very rarely seen and the samples have no material value. To liberate gold requires complex metallurgical processing at the concentrator and smelter, which are long-established operations and it would benefit no-one to interfere with drill-core samples to create a false understanding of part of the deposit. To have any material effect on the Mineral Resource estimate, a very large number of samples would need to be tampered with. This would be detected from existing QAQC processes and reconciliation between mine and mill production data.

### **3.19 Assay data and laboratory investigation**

Sample preparation, chemical assaying and measurements of specific gravity is carried out by ALS Piteå – Geochemistry, Hammarvagen 22, SE-943 36 Ojebyn, Piteå Norrbotten, Sweden.

All ALS geochemical hub laboratories are accredited to ISO/IEC 17025:2017. As part of the QAQC processes, pulp duplicates are sent from ALS to Hazen Research (Colorado, USA) for Te analysis. Table 8 shows an overview of the methods used. The “Over-range method” applies to samples where assay result reached upper detection limit of the primary method.

Table 8. Overview of ALS’s designation of analytical methods.

	Method	Over-range method
Preparation	PREP – 22	
Assay Au	Au-ICP21	Au-GRA21, Au-AA25
Assay other	ME-MS61	Ag-OG62/Ag-GRA21, S-IR08, Te-AA62, (As, Cu, Pb, Zn)-OG62
Specific gravity (core)	OA-GRA08	
Specific gravity (pulp)	OA-GRA08c	

Au-ICP21 is a package of fire assay with an ICP-AES analysis. ME-MS61 is a package of a 4-acid digestion process with an ICP-MS analysis. The Periodic table of elements in Table 6) show which elements (marked in yellow) are assayed for at the Kankberg mine. Results are available in the drilling database, held in acQuire™ software.



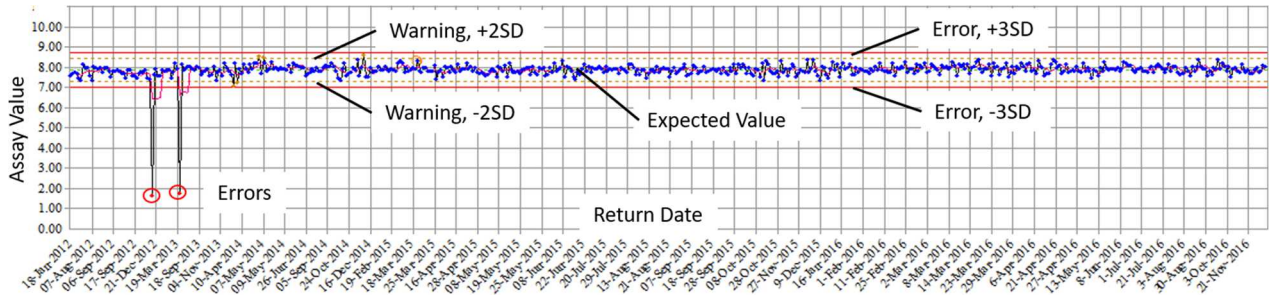

Figure 17: Graph of results for a gold assay standard, from submitting in batches from 2012 to 2016.

Results from the submission of duplicates since 2011 are not available at the time of writing. However, this was a matter for careful attention in the FS. The main assay laboratory used was ALS Chemex in Canada, and 1 in 20 samples were sent for a check assay for gold to RCA Rönnskär smelter and 1 in 40 samples were checked for tellurium at Hazen Research Lab, USA. The differences in both cases (Au & Te) were very small.

### 3.20 Verification of results

Data acquired before 1995 are not used for estimation. The majority of drilling in the 10m x 10m drilling density used to bring Mineral Resources up to Measured category takes place a few years or months before mining. Consequently, there is no need for twinned holes or deflections to confirm ‘old’ data. Rather than using duplicates to confirm assays from a relatively low drilling data density, it is accepted that individual sample gold grades will be erratic. This is illustrated in the Probability Graph in Figure 18 (includes data up to November 2019), where the gold grades span over 5 orders of magnitude. The gold trace on this plot shows a very smooth, single population log normal distribution, that would be very hard to produce if the data was of poor quality or had been tampered with. Refer to the book “Applied Mineral Inventory Estimation” by Sinclair and Blackwell (2002) for an explanation of these graphs.

A high drilling data density (with top-cutting, described later) is applied to minimize any local mis-estimation that the erratic values may cause. Essentially, the closely-spaced drilling and large number of samples takes the operational place of the use of twinned holes, deflections or duplicate samples.

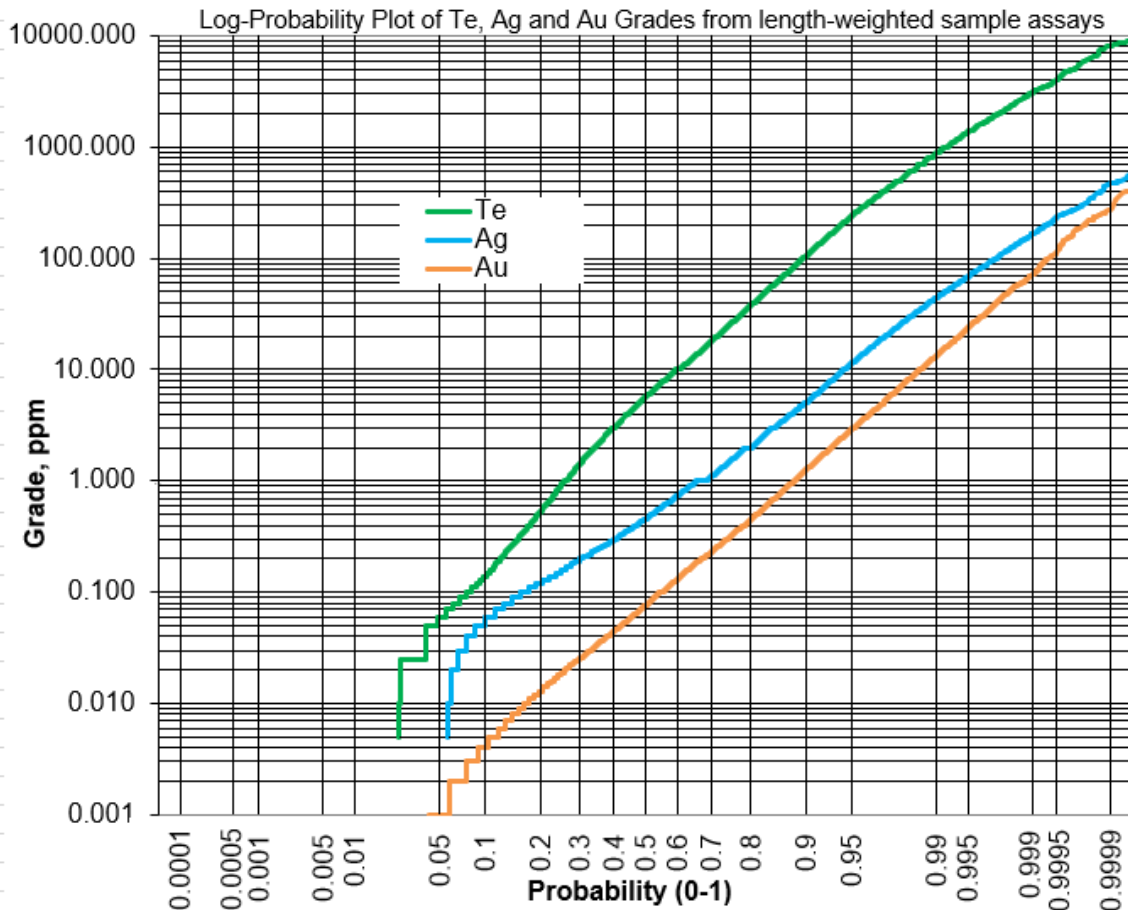

Figure 18: Probability Graph of Te, Ag and Au Length-Weighted Grades from the entire database of drill sample assays (Nov 2019).

Verification of selected intersections by either independent or alternative personnel has not been done. It is not considered necessary, since at this well-established operation with its production history, the reconciliation results, discussed under ‘History’ above, demonstrate that the existing approach of a high data density is adequate.

### 3.21 Data location

Mine surveying is carried out using a Leica Viva TS15 total station. Survey data management is carried out in Powel Gemini Terrain software. Examples of mine survey plans using the coordinate system G1NSYSTEMET are given in Appendix 2. It is considered that these plans are of excellent quality.

Hole collars are surveyed before drilling and again afterwards. For exploration drilling, downhole deviation surveying is carried out by Protek AB personnel using an Inertial Sensing isGyro instrument. About 10 drill holes have been deviation surveyed using a Reflex Gyro instrument. For infill drilling, deviation surveying is carried out by Kankberg personnel using a Devico DeviFlex or a Reflex Maxibor II instrument. Deviation surveys are checked on drillhole plots and rarely, if there are features such as unnatural kinks, certain data may be identified to be in error and are not included. These are detailed in the “Data Hand-Over for Block Model” report, as mentioned earlier.

### 3.22 Data density and distribution

The sections above discuss high data density produced by the 10mx10m drill spacing that is required for classification as Measured Mineral Resources and hence Proved Mineral Reserves. Indicated and Inferred classifications require less-close spacings, and these are described below in Section 3.37, 'Classification'.

The orientation of the drilling is mainly at a range of angles around a dip of 0° (i.e. around horizontal) and around the west-east direction. This is near to perpendicular to the vertically orientated mineralized lenses which have a strike around north-south. It is considered that, as far as is reasonably achievable, the orientation of sampling achieves unbiased sampling of significant structures, i.e. the gold mineralized lenses. Given the deposit type, these are reasonably clearly identifiable at an appropriate stage of the progressive infill drilling.

The spacings and orientations are illustrated in a series of representative plans and profiles, each with a depth of view of 20m. At the mid-point of that depth are shown colour-coded block model NSR grades. NSR is 'Net Smelter Return', as described below under 'Metal equivalents or other combined representation of multiple components'. In effect, it is the value of the gold grades since the by-products add little value. These plans are given in Appendix 4 using the G1NSYSTEMET coordinate system.

Particularly due to the reconciliation results described above under Section 3.3, 'History', but also given understanding of the style of mineralization and of other similar deposits, it is considered that data density and distribution are sufficient to establish the degree of geological and grade or quality continuity appropriate for the Mineral Resource and Mineral Reserve estimation procedure and classifications applied.

### 3.23 Reporting Archives

WellCAD™ software is used for logging data capture. This software includes validation criteria to detect and minimise human error. All data transfer is electronic, including the initial logging and the transfer of assay data from files from the laboratory. Assays and other data are loaded into the acQuire™ database system. Digital data is stored on a central server that is managed by Boliden's IT group, with appropriate security and back-up protocols.

### 3.24 Audits or reviews

Sampling techniques and data have not been independently audited. However, the independent review carried out by Mr Howson during 2019, confirms that:

- procedures are aligned with industry best practice;
- are internally consistent; and
- the data are consistent with both what has been observed in core and underground, and similar deposits of this type.

NB. PERC 'Table 1 Part 3 - Reporting of Exploration Results' is omitted from discussion in this section of the report, given the advanced stage and production history of the Kankberg operation.

### 3.25 Database integrity

As discussed briefly in Section 3.16 above, Boliden has standard operating procedures for the use of WellCAD™ for core logging data, combined with transfer into acQuire™ limit



common errors in data capture, risks associated with data transfer, integration with assay results and subsequent search and extraction into modelling and estimation applications.

Before the block model is updated the new data added is reviewed by responsible geologists. The review is aided by validation and flagging tools in acQuire. Drill hole collar is validated and deviation survey data is passed for quality. The logging, sampling and assay data are assessed for overlaps, gaps or duplication.

Any deviations are detected during this process and dealt with appropriately to limit influence on the subsequent modelling and estimation process. This process ensures database integrity and as a basis for estimation.

The report for the most recent Mineral Resources estimate update, of 11<sup>th</sup> November 2019 indicates the numbers of assay results, as listed in Table 10. Large portions of this report are reproduced in edited form herein, to describe the data investigations, geological interpretation and estimation and modelling techniques.

Table 10: Number of drill holes and number of assays per element in the Kankberg database supporting the current estimate

Number of Drillholes	Number of Assay Results					
	Au	Ag	Te	Cu	S	Bi
2 122	138 156	138 166	124 976	132 886	134 399	125 327

### 3.26 Geological interpretation

Using commercially available software packages (Leapfrog, Datamine Studio, Snowden Supervisor) a 3-dimensional block model is created into which grade estimations are interpolated. The project limits and coordinates are in G1NSYSTEMET. The model extents and parameters are outlined in Table 11. The parent block size of 6x6x6 m is based on drill hole spacing of approximately 10-20 m. For short term planning purposes, a sub-blocked model with block sizes down to 1.5 m is created.

Table 11: Block Model Parameters

Axis	Origin coordinates	Cell size, m.	Number of cells	Extent, m.	Far corner coordinates
X	3897	6	110	660	4557
Y	997	6	90	540	1537
Z	-753	6	110	660	-93

The mineralisation wireframes used for domaining were created in Leapfrog Geo 4.5. Au grades of 2 ppm, 1 ppm, and 0.5 ppm were used as thresholds for the High, Low, and Waste grade interpolants respectively, as shown in Figure 19. These threshold grades roughly reflect historic cut-off grades and are used to reduce smoothing and produce a more local grade estimate. No changes to the parameters defining the generation of the high, low and waste grade wireframes in Leapfrog have been applied so this is in line with previous updates. Overall the leapfrog wireframes show little change from those in 2018\_2 and 2019\_1. However, there are minor changes, mostly related to new drilling information.

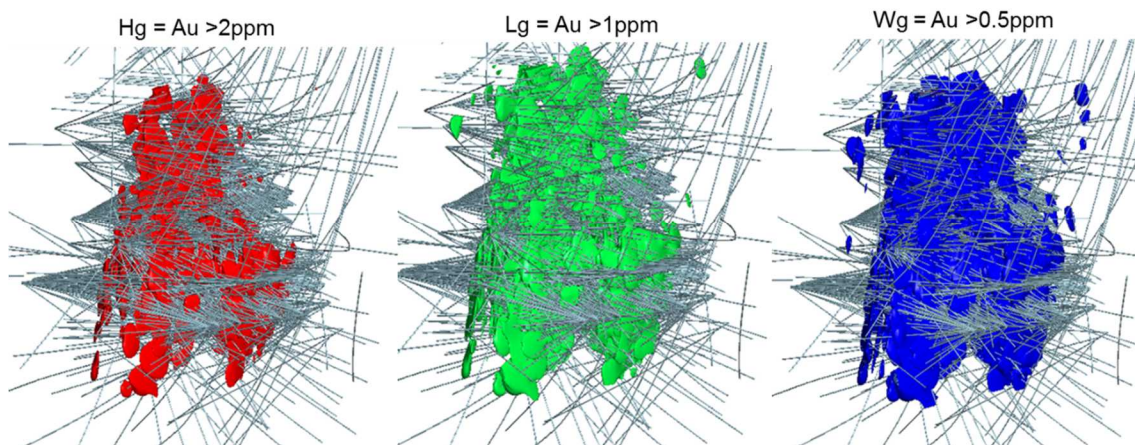

Figure 19: Grade shells created in Leapfrog based on Au ppm values.

### 3.27 Estimation and modelling techniques

In the horizontal plane, the 5 mineralized zones of which the deposit is informally comprised occur together in a roughly oval shape that extends about 355 m in the X direction in G1NSYSTEMET which may be called the strike direction, but almost N-S in the national grid, and about 225 m in the Y-direction, or E-W in the national grid. Vertically it extends about 530 m.

Initial univariate statistical analysis is shown for the High, Low, and Waste grade interpolants respectively in Table 12. Notably high coefficients of variation (“COV”) are reported for all mineralisation variables.

Table 12: Initial length weighted and domain statistics. COV greater than 1.5 has been marked red.

ZONE	FIELD	NRECORDS	NSAMPLES	MINIMUM	MAXIMUM	MEAN	STANDEV	WGTFIELD	COV
HG	LENGTH	16738	16738	0.0	14	1.8	0.4	LENGTH	0.2
	AU_PPM	16738	16690	0.0	859	5.7	20.7	LENGTH	3.6
	AG_PPM	16738	16690	0.0	4340	13.5	53.3	LENGTH	4.0
	TE_PPM	16738	16087	0.0	30600	241.0	614.6	LENGTH	2.6
	BI_PPM	16738	16087	0.0	10000	131.6	415.8	LENGTH	3.2
	CU_PCT	16738	16212	0.0	8	0.0	0.1	LENGTH	5.4
	S_PCT	16738	16361	0.0	47	0.9	2.9	LENGTH	3.2
LG	LENGTH	14686	14686	0.0	14	1.8	0.5	LENGTH	0.2
	AU_PPM	14686	14622	0.0	28	1.1	1.5	LENGTH	1.3
	AG_PPM	14686	14622	0.0	273	5.0	10.7	LENGTH	2.1
	TE_PPM	14686	14029	0.0	8900	110.8	245.9	LENGTH	2.2
	BI_PPM	14686	14029	0.0	8990	64.1	180.0	LENGTH	2.8
	CU_PCT	14686	14179	0.0	4	0.0	0.1	LENGTH	5.0
	S_PCT	14686	14280	0.0	49	1.0	2.7	LENGTH	2.8
WG	LENGTH	14773	14773	0.0	11	1.9	0.4	LENGTH	0.2
	AU_PPM	14773	14668	0.0	10	0.5	0.6	LENGTH	1.2
	AG_PPM	14773	14669	0.0	478	2.7	8.6	LENGTH	3.2
	TE_PPM	14773	13950	0.0	9040	67.0	197.0	LENGTH	2.9
	BI_PPM	14773	13950	0.0	10000	43.6	171.4	LENGTH	3.9
	CU_PCT	14773	14187	0.0	5	0.0	0.1	LENGTH	4.4
	S_PCT	14773	14312	0.0	49	1.5	3.2	LENGTH	2.2

Histograms and Log probability plots were used to identify the presence of outlier grades for samples of element Au, Ag, Te and Bi. The top-cuts in the 2019\_2 update are in line with top-cuts in previous Mineral Resource estimate and these are presented in Table 13.

Table 13: Summary of top cut values applied

Assay	Top-cut	Total number of assays	Number of assays cut	% of number of assays cut	Raw Assay Mean	Grade Capped Mean	Difference [%]
AU_PPM	75	45980	147	0.3	2.66	2.359	-11.2
AG_PPM	200	45981	99	0.2	7.53	7.08	-6.0
TE_PPM	1500	44066	565	1.3	151.00	132.00	-12.6
BI_PPM	1500	44046	267	0.6	86.00	77.00	-10.5

Un-assayed sections of the drillcore have been treated as core-loss, i.e. samples with missing assay results have been set to absent.

Drill core samples are usually taken at 2 m length within geological domains. More than 50% of the samples have a length of exactly 2 m. Length-weighted composites with a target length of 2 m were calculated for the grade estimation process, as for previous estimations. Figure 20 below presents a plot of composite length against average gold grade, with bubble size representing the number of samples in each of the three domains (high grade = HG, low grade = LG and waste = WG).

In the HG Domain it can be seen that composites that are both longer or shorter than the target length, tend to be of lower grade than the mean of about 5 g/t. This is because they are likely to be mainly derived from relatively short peripheral intersections, that may be of lengths that do not neatly sub-divide into 2 m segments, and which are generally of lower grade than more central and longer intersections. This effect seems reasonably symmetrical about the target length. All composites are given the same ‘weight’ or influence in estimation by Kriging, so the risk is that short composites may have an unduly large influence, and long composites have an unduly low influence. But in this case, because of the symmetry, it seems that bias from short and long composites cancel each other out. Therefore it is considered that, overall, there is no evidence that bias has been introduced during the compositing process.

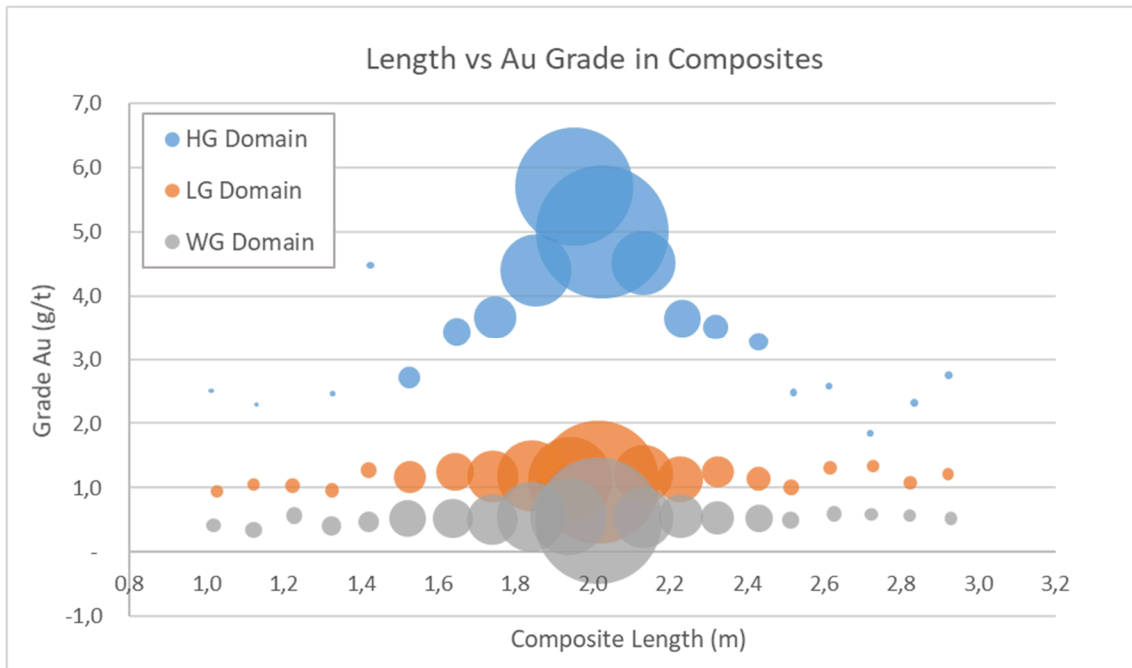

Figure 20: Length (m) vs gold grade (g/t) in composites

In the most recent model update, variogram parameters have been reviewed and are in line with previous used parameters (2018\_2, 2019\_1). Datamine’s dynamic anisotropy has been used so that the estimation search ellipsoid and variograms are aligned with the structural trends as interpreted within Leapfrog. Table 14 lists all variogram parameters.

Table 14: Semi-variogram parameters for all estimated elements

ASSAY	VRFNUM	VANGLE1	VANGLE2	VANGLE3	VAXIS1	VAXIS2	VAXIS3	NUGGET	ST1	ST1PAR1	ST1PAR2	ST1PAR3	ST1PAR4	ST2	ST2PAR1	ST2PAR2	ST2PAR3	ST2PAR4
AU_PPM	1	25	50	120	3	1	3	0.4	1	12	12	5	0.6					
AG_PPM	2	25	50	120	3	1	3	0.4	1	12	12	5	0.6					
CU_PCT	3	25	60	105	3	1	3	0.25	1	25	25	25	0.6	1	65	65	65	0.15
S_PCT	4	25	60	105	3	1	3	0.08	1	25	25	25	0.66	1	90	90	90	0.26
TE_PPM	5	25	50	120	3	1	3	0.3	1	12	12	5	0.7					
BI_PPM	6	25	70	120	3	1	3	0.4	1	11	12	5	0.6					

Ordinary Kriging was used for the grade estimation of Au, Ag, Te, Cu, Bi and S. It used an orientation of the search ellipsoid that is in line with previous estimations. The search ellipsoid is defined by the orientation of the variogram model. A table of used search ellipsoid parameters is presented in Table 15.

Table 15: Search ellipsoid parameters

SDESC	SREFNUM	SMETHOD	SDIST1	SDIST2	SDIST3	SANGLE1	SANGLE2	SANGLE3	SAXIS1	SAXIS2	SAXIS3	MINNUM1	MAXNUM1	SVOLFAC2	MINNUM2	MAXNUM2	SVOLFAC3	MINNUM3	MAXNUM3	OCTMETH	MINOCT	MINPEROC	MAXPEROC	MAXKEY
AU_PPM	1	2	15	15	8	25	50	120	3	1	3	5	10	2	5	10	5	1	10	0				5
AG_PPM	2	2	15	15	8	25	50	120	3	1	3	5	10	2	5	10	5	1	10	0				5
CU_PCT	3	2	20	20	20	25	60	105	3	1	3	10	20	2	10	20	5	1	20	0				5
S_PCT	4	2	20	20	20	25	60	105	3	1	3	10	20	2	10	20	5	1	20	0				5
TE_PPM	5	2	15	15	8	25	50	120	3	1	3	5	10	2	5	10	10	1	10	0				5
BI_PPM	6	2	15	15	8	25	70	120	3	1	3	5	10	2	5	10	10	1	10	0				5

The minimum number of composites required for a block estimate is five (Cu and S: 10) and the maximum is ten (Cu and S: 20). If the search did not meet the requirements it was doubled in size. The minimum and maximum parameters remained unchanged. In case the expansion of the search volume did not succeed to meet the search requirements the search distances were multiplied by five (Te and Bi: 10) and the minimum number of composites was reduced to one. A maximum of five composites was allowed to contribute from any drill hole.

In order to check that the estimation strategy applied is appropriate, the model was validated using different techniques. These include:

- a statistical comparison of composite against block model estimates;
- validation plots to compare the block model estimates against informing composites along different slices through the deposits; and
- Visual validation of block estimates against informing composites.

In order to compare the model results to the input data a comparison table of block model global mean grades and composite (top-capped) mean grades has been prepared (Table 16). Deviations greater than 10% are marked by red. Au is overestimated compared to the capped composite grades in the HG-zone. The deviations are significant but at this point accepted and an investigation to explain the deviations is recommended. This model update was in line with previous models, models that corresponds well to the production reconciliation.

Table 16: Comparison of block estimates and composites (top-capped). Deviations greater than 10% in red.

ZONE	FIELD	NSAMPLES	MINIMUM	MAXIMUM	MEAN	STANDEDEV	Composite Mean	Composite standard dev	Mean diff	Mean diff %
HG	AU_PPM	13063	0.016	63.291	5.624	4.619	4.91945	9.098166	0.7	14
HG	AG_PPM	13063	0.1	108.31	11.69	12.45	12.35907	22.96558	-0.7	-5
HG	TE_PPM	13063	1.858	1426.198	210.235	187.764	204.7338	301.3949	5.5	3
HG	BI_PPM	13063	0.507	1156.738	123.891	146.342	114.1744	220.8502	9.7	9
LG	AU_PPM	12734	0.01	5.723	1.105	0.549	1.14	1.35	0.0	-3
LG	AG_PPM	12734	0	65.07	4.4	5.08	4.99	9.82	-0.6	-12
LG	TE_PPM	12734	0.985	1070.005	95.697	103.707	106.47	189.79	-10.8	-10
LG	BI_PPM	12734	0.293	960.513	57.447	78.216	62.24	141.50	-4.8	-8
WG	AU_PPM	18229	0	2.537	0.529	0.243	0.51879	0.599362	0.0	2
WG	AG_PPM	18229	0	40.33	2.62	3.28	2.6724	6.473042	-0.1	-2
WG	TE_PPM	19229	0	845.344	58.647	71.39	64.29316	143.4327	-5.6	-9
WG	BI_PPM	18229	0	926.049	38.194	63.419	41.17099	119.4043	-3.0	-7

As part of the validation process, the block model and input composites that fall within defined sectional criteria were compared and the results displayed graphically to check for visual discrepancies between grades on 6 m north-south sections.

This validation quickly highlights areas of concern within the model. Each graph also shows the number of samples available for the estimation, which provides information relating to the support of the blocks in the model. The validation plots give a qualitative indication to the amount of smoothing that has been introduced into the model. Figure 21 an example of an Au validation trend plot, also known as a ‘Swath Plot’.

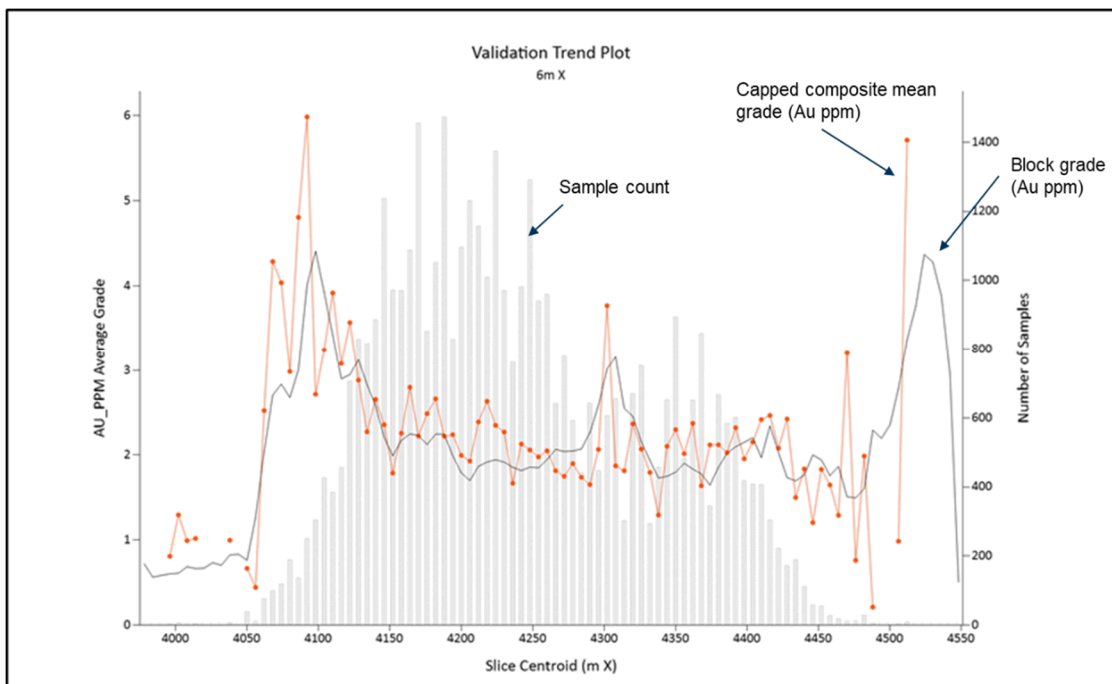

Figure 21: Au Validation Trend Plot showing 6m north-south sections. Red line represents capped composite mean grades and black line represents block grades.

In this plot, where there are the most composites, such as between 4150 and 4250, the blocks appear to be under-estimated relative to the means of the composite grades. But this effect is probably due the large numbers of composites in volumes with 10x10 metre drilling (see later) that is used to upgrade to Measured Mineral Resource category, relative to much smaller numbers that are lower-grade and in peripheral volumes, that may not have been upgraded to this category. Overall, it is considered that the block estimates reasonably reflect the input sample data.

### 3.28 Metal equivalents or other combined representation of multiple components

For revenue evaluation, a ‘Net Smelter Return’ (NSR) value is calculated for each model block from the metal prices, costs of processing and smelting, and metallurgical recoveries. The NSR is effectively the value in Swedish Kronor (SEK) for each gram of each contained product or by-product metal attributed to ore arriving at the BOAPP from Kankberg, within Boliden’s accounting system. Being a combined product value, it is used as a grade to describe tonnages in terms of SEK/t.

In Table 17 below, the long-term NSR Factors are given for each element in the first column, along with the projected average grades and NSR value per tonne over the Life of Mine (LOM). The 5<sup>th</sup> column provides percentage revenue contribution from each element to the overall operation.

Table 17: Long-Term Net Smelter Return Factors and associated information

Element	NSR Factor, SEK/g	Average LOM Grade, g/t	Average LOM NSR Value, SEK/t	Average LOM Revenue Contribution, %
Au	288	3.78	1 089	97%
Ag	1.46	10	14	1.3%
Te	0.13	171	22	2.0%

Refer also to Section 3.34, Costs and Revenue Factors for further explanation.

### 3.29 Cut-off grades or parameters

The basis for defining Mineral Resources is that:

- (a) the material is above the marginal cut-off grade of 300 SEK/t; and
- (b) is included within the LG (low grade) and/or HG (high grade) domain and not waste (WG) domain.

Using NSR as calculated above, a break-even mining cut-off grade of 525 SEK/t is used to guide mining design and in Mineral Reserve and additional Resource Estimation (see Section 3.34, ‘Cost and revenue factors’). When rock below this cut-off must be mined, mainly to access higher-grade material, a marginal cut-off of 300 SEK/t is applied and this material trucked as ore. Rock below 300 SEK/t would be mined as waste and used within the mine as fill.

For production planning and Reserve classification, the entire room must average at least 525 SEK/t to be mined (this could include material which has a grade below 525 SEK/t).

See Table 18 below for a summary of operational (break-even) and marginal cut-off grade assumptions, based on current operating costs and long-term price assumptions.

Table 18: Cut-off grade & NSR assumptions

<b>Cut-off grades</b>	<b>NSR, SEK/t</b>	<b>Metal grades corresponding to NSR cut-off*</b>	<b>Au grade corresponding to NSR cut-off</b>
Operational (Break-even)	$\geq 525$	$\geq 1.77$ g/t Au $\geq 4.67$ g/t Ag $\geq 81$ g/t Te	$\geq 1.82$ g/t Au
Marginal	$< 525$ and $\geq 300$	$\geq 1.01$ g/t Au $\geq 2.67$ g/t Ag $\geq 46$ g/t Te	$\geq 1.04$ g/t Au
Waste	$< 300$	$<$ ‘Marginal’ grades as given above.	$<$ ‘Marginal’ grades as given above.

\*Given the forecast average relative revenue contribution from each metal over the life of mine.

### 3.30 Tonnage Factor/In-situ Bulk Density

Two density figures are assumed for estimation of the deposit:

- 2.9 t/m<sup>3</sup> is used for material classified as ore.
- 2.8 t/m<sup>3</sup> is used for material classified as waste rock

The figure for ore was determined during the FS for the mine when 71 density measurements were made in 1998 and between 2004 and 2005 in Piteå (SGS Piteå, Piteå ALS Chemex) from samples taken from all the major rock types within the mineralisation. The figure for waste is an assumption based on the lower level of alteration in waste rocks.

Recognizing that there is an opportunity to improve accuracy, since February 2018 Boliden Mineral AB has been requesting measurements of specific gravity of drill core samples along with chemical assays. Every fifth sample is measured using the Archimedes principle and all samples are measured using a pycnometer. An evaluation of the measurements is ongoing.

As shown in the mine-mill reconciliation above under ‘History’, the total mine tonnage for 2012 to 2020 differs from the mill tonnage for the same period by 1%. Therefore, it is considered that the densities presently used are ‘on average about right’. However, more work on density is considered to be worthwhile, since it may lead to an improvement in weighted averaging of Mineral Resources grades.

### 3.31 Mining factors or assumptions

The mining method in the Kankberg Mine is a cut-and-fill process that can also be described as room-and-pillar with fill. The ore is mined in 6 m high horizontal rooms or stopes (7 m if it is a bottom room). The rooms are stacked vertically in 4 to 6, into levels, which are accessed from the ramp, as shown in Figure 22 (left). The mining starts from a bottom undercut and advances upwards. As shown in Figure 22 (right), the mining cycle is comprised of drilling of the ore, loading of blast holes, blasting, loading of the ore, cleaning of the exposed rock and reinforcing with cemented iron rods and shotcrete.



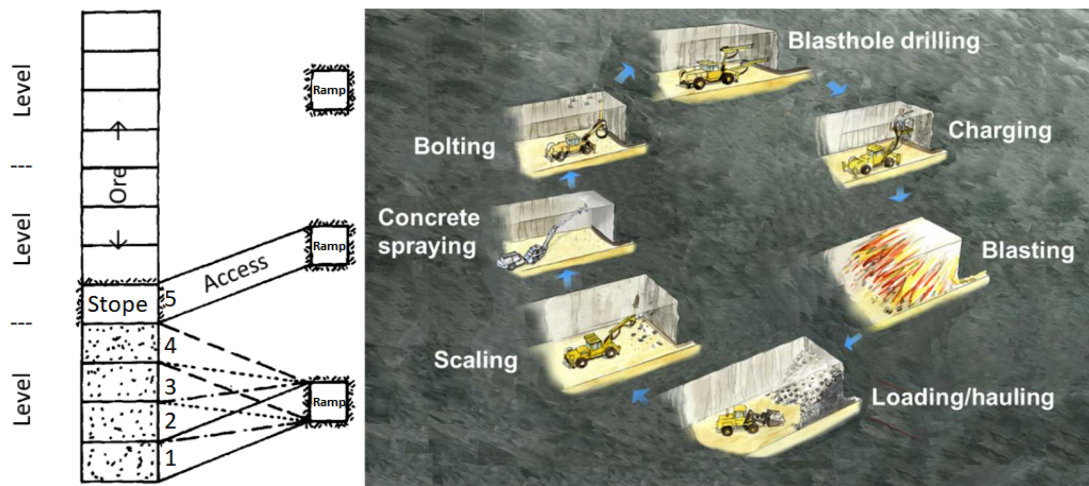

Figure 22: (Left) Sketch profile showing stope access. (Right) Illustration of the mining cycle.

Once the stope is mined, media like water, power supply and ventilation are retreated, as the stope is backfilled with waste material. The fill material serves both as support for the stope walls and as working platform for the next stope. The width of stopes varies between 4.5m to 10m. Where the width of the stope exceeds 10 m, pillars of 6 x 6 m are left at 10 m intervals within the stope. On average 4 to 5 different stopes are in production at any given time with one primary backfill area.

For a better understanding of the arrangement of the pillars, it is recommended to peruse the survey plans given in Appendix 3. Pillars on successive levels are vertically aligned.

In the FS, there were 292 observations giving Rock Mass Rating (RMR) of which 90% were RMR > 60 and 100% were RMR > 25. It was determined that the unstable zone is 8 to 19 m. This determined the span between pillars of 10 m, with the use of rock bolting and shotcreting using fiber-reinforced concrete.

Even though all of the orebody lies below the water level of nearby lakes, because of the impermeability of the rocks (and the plugging of drill holes) the dewatering costs are low.

Mining costs are summarised above in Section 3.29, “Cut-off grades or parameters“, where they are used to determine a break-even cut-off grade.

Backfill uses waste rock either from elsewhere in the mine, which comprises around 51% of the requirement, or waste material trucked in from Rönnskär. The requirement for the current Life of Mine Plan is 2.3 Mt of waste rock. There are several historic waste dumps within an acceptable distance of the mine with quantities exceeding the remaining requirement, which Boliden consider would be suitable for backfill.

Essentially, in the present operation of the mine, conversion of the Mineral Resource to a Mineral Reserve mainly consists of the three-dimensional planning of the rooms or stopes and what material will be left behind as pillars.

As indicated by the reconciliation under ‘History’ above, the performance parameters are considered to be reasonably reliable.

### 3.32 Metallurgical factors or assumptions

The process used is well established. The ore is delivered by truck to the BOAPP, weighed by truck weigh-bridge and either delivered directly into the plant or stockpiled separately from ore from other mines. Ores from the different mines are processed in batches or campaigns. The feed tonnage to the processing plant is measured using a weighing system with a stationary belt scale. The feed tonnage and the truck weights are used to determine current tonnage in the stockpiles.

As shown in Figure 23 below, there are two stages of grinding. The primary mill is a fully autogenous mill and the secondary mill is a pebble mill fed with pebbles extracted from the primary mill. The ground ore is classified using screens and hydro-cyclones. A gravimetric concentrate containing coarse grained gold bearing minerals is produced in the grinding circuit. The gravimetric concentrate is packed in bags of about 800 kg and delivered to the Rönnskär smelter by truck.

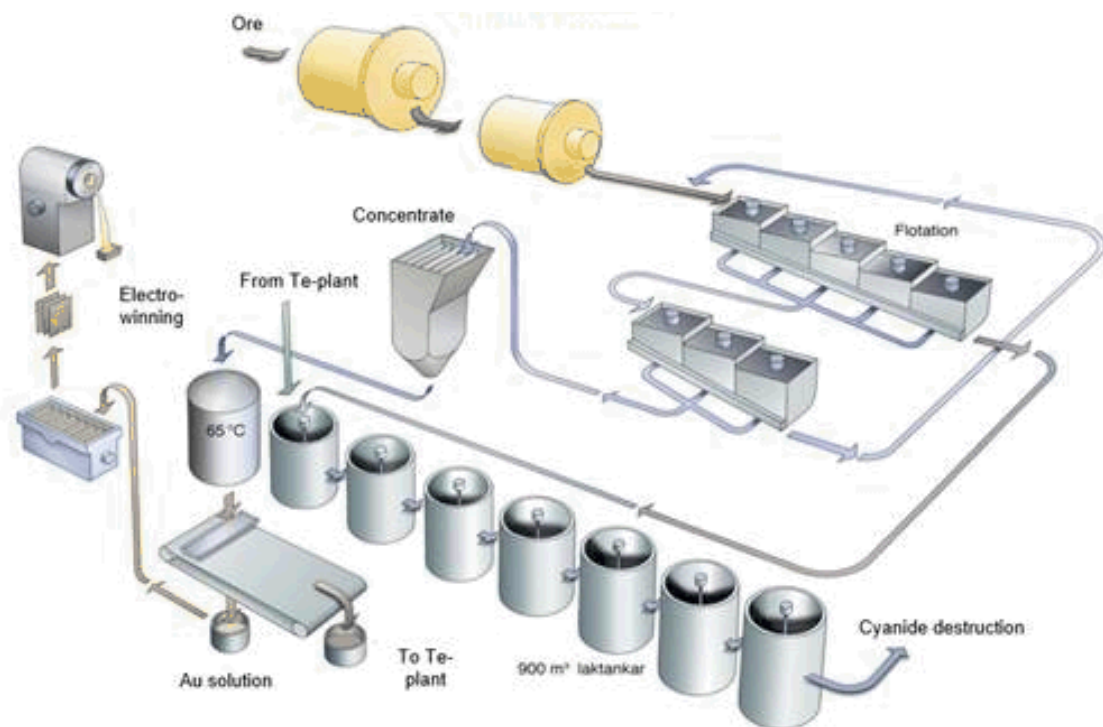

Figure 23: Simplified overview of the different stages of Kankberg ore processing at BAOPP.

Flotation is used to produce a precious metals and tellurium concentrate. The concentrate is accumulated in a leaching tank over a four to five-week campaign. After the completion of a campaign, the concentrate is hot cyanide leached to extract precious metals as a solution. This is done as a batch process. This solution is then separated from the tellurium-rich leach residue using a belt filter. The solution is pumped through a column containing active carbon to recover precious metals. These are then stripped from the carbon as a solution. Electrowinning is used to precipitate the precious metals in the solution to a sludge that is melted and cast into doré bars that are delivered to the smelter.

The tellurium-rich leach residue is stored in a tank so that onward processing can proceed continuously. The residue is leached again in a proprietary process to recover the tellurium to a tellurium concentrate 'cement'. This is a grey-black powder containing principally tellurium and bismuth oxides with 10% moisture. It is packed in steel drums for sale.

Also, in a continuous process, the residue from the tellurium process is added to the flotation tailings which are cyanide-leached at ambient temperature in a CIL process using active carbon. The active carbon is stripped to produce a solution containing precious metals. In the same process, but not at the same time as the batch described above, electrowinning is used to precipitate the precious metals in the solution to a sludge that is melted and cast into doré bars that are delivered to the smelter.

Metallurgical accounting where a sum of products calculated using assays from daily composite samples of main process streams and assays and tonnage for delivered products together with feed tonnage is used to determine the head grade of the ore.

Metallurgical recoveries are presented in Table 19 below.

Table 19: Metallurgical Recoveries

Product	Metallurgical Recovery
Au	86%
Ag	36%
Te	51%

At the time of writing, metallurgical testwork was being undertaken on a zone of Indicated category, sulphide-rich material in the upper parts of the Kankberg mine. This material displayed different metallurgical properties compared to that of standard Kankberg ROM ore and maybe incorporated into the Life of Mine Plan (LoMP), subject to results of process testwork and other factors as discussed elsewhere in this report.

### 3.33 Mineral Resource estimate for conversion to Mineral Reserves

Mineral Resources are converted into Mineral Reserves when the rooms that will mine them are planned, and that material left in pillars can be excluded from the Mineral Reserves. All other modifying factors, namely processing, metallurgical, infrastructure, economic, marketing, legal, environmental, social and governmental factors, that are required to transfer Mineral Resources to Mineral Reserves are already in place and considered to be favourable. If, for example, potentially economic mineralization was found by drilling at Kankberg that required different processing to that presently used for Kankberg ore, then this material would require a separate Feasibility Study to develop a separate mine with separate mineral asset reporting (see Section 3.32, for a brief discussion of on-going metallurgical test-work on Inferred material in the upper parts of the Kankberg mine).

Mineral Resources are classified into Measured, Indicated and Inferred categories. Only small portions of the block model remain unclassified. The Mineral Resource classification is based upon evaluation of drill hole density and continuity of mineralization. Generally, a sample spacing of at least 60x60 meters is required for Inferred, 20x20 meters is required for Indicated and 10x10 is required for Measured. The assignment of these categories is carried out by manual review, with reference to drilling layouts and with regard to geological complexity.

Mineral Reserves are selected and reported from the parts of the block model which fall within mining design volumes (LoMP), which could include Inferred Mineral Resources. Material that falls outside the mine design is defined by wireframes and is reported as Mineral Resources exclusive of Mineral Reserves.

Where mining design volumes include Measured and Indicated Mineral Resources, then these are transferred into Proved and Probable Mineral Reserves, respectively, but excluding material in pillars. It may include small quantities of material that are Inferred Mineral Resources that are not transferred. The volumes of the categories are illustrated in three 3D views in Appendix 5. Vertical pillars are included in the mine design but are not transferred into Mineral Reserves, but because they are now in the mining design volumes, they are not reported. The Mineral Resource is the portion of the block model that is within the high-grade shell (i.e. mainly > 2 g/t gold) and within the low-grade shell (i.e. mainly > 1.1 g/t gold) with a NSR value  $\geq$  300 SEK/t. It includes sill pillars and Inferred Mineral Resources that lie within the LoMP.

Mineral Reserves and Mineral Resources are estimated from the block model using the above wireframes to allocate the categories. Because of the way in which blocks are assigned, Mineral Resources are always reported as additional to Mineral Reserves.

The Mineral Resources and Reserves are estimated with waste rock dilution and recovery percentage per category according to Table 20.

Table 20: Waste rock and dilution per category

Waste rock dilution (%)	Recovery (%)	Category	
3.5	100	RESCAT=1 (Proved)	Reserve
15	85	RESCAT=2 (Probable)	Reserve
3.5	90	RESCAT=3 (Measured)	Resource
15	75	RESCAT=4 (Indicated)	Resource
20	70 to 80	RESCAT=5 (Inferred)	Resource

In effect, Measured Mineral Resources are similar to Proved Mineral Reserves, except that the pillars are explicitly omitted from the Proved Mineral Reserves, whereas in the Measured Mineral Resources, the pillars have not been planned, but they are implicitly omitted by the Recovery Factor. The same relationship exists between Indicated Mineral Resources and Probable Mineral Reserves.

For further discussion, see Section 3.38, ‘Audits or reviews’ below.

### 3.34 Cost and revenue factors.

Mining, transportation and processing costs are outlined in Table 21.

Table 21: Mining, transport and process operating costs

	<b>Costs (SEK/t)</b>
Mining (except transport of ore in mine)	335
Ore transport	65
Process (without fixed expenditures)	125
<b>Total</b>	<b>525</b>

The total of these costs gives the break-even cut-off used for mine planning, as described above under Section 3.29, 'Cut-off grades or parameters'.

Boliden's planning prices, which are an expression of the anticipated future average prices for approximately 10 years, are presented in Table 22 below.

Table 22. Long-term metal prices and currency exchange rates

<b>Metal prices</b>		<b>LTP</b>
		<b>2022-&gt;</b>
Gold	USD/tr.oz	1 300
	SEK/kg	334 368
Silver	USD/tr.oz	17.0
	SEK/kg	4 373
Tellurium	USD/kg	30
	SEK/kg	240
<b>Currency rates</b>		<b>LTP</b>
		<b>2022-&gt;</b>
USD/SEK		8.00
EUR/SEK		9.35
EUR/USD		1.17

The metal prices given here and the metallurgical recoveries given above in Table 19 under Section 3.32, 'Metallurgical factors or assumptions', provide two of the three parameters that are combined to give the Net Smelter Return factors, in Table 17, under Section 3.28, 'Metal equivalents or other combined representation of multiple components'. Therefore, it would be possible to calculate a combined processing and smelter cost for each of the three products. However, this would be a cost per gram of product, which would only be realistic when the grades and proportions are as they are expected to be over the life of mine. In reality, operating costs are composed of both fixed and variable components relating to operation production rate or through-put. Due to the complexity and confidentiality of the costs associated with processing and smelting, no further details are presented here.

### 3.35 Market assessment.

International supply and demand for gold and silver do not need explanation here, and Boliden does not stockpile these metals. Including metal from Kankberg, gold and silver in concentrates and doré bars from the BAOPP are smelted at the Rönnskär smelter. This is

100% owned by Boliden Mineral AB and situated at Skelleftehamn, the port near Skellefteå. It produces roughly 18,000 kg of gold as bars or granules every year. Of that amount, approximately 5,000 kg is recovered from electronic scrap, and the rest is from Boliden and external mines. The major part of the gold is sold to the jewellery industry, but the manufacturing industry and the financial sector are also important customers.

The smelter also produces 450,000 kg of silver every year, exceeding 99.99% purity of which about 110,000 kg is from electronic scrap. It is sold to the electrical, electronics and jewellery industries in the form of granules.

The main market for tellurium is in China. Its price has fallen in recent years and there is a risk that the Mineral Resources and Reserves could be reduced slightly if no value can be ascribed to tellurium. However, it is considered that this would not have a material impact on the economic viability of the Kankberg operation. It should be noted that variation in the gold price and foreign exchange rates have a much greater influence on the economics of the operation than whether or not the Kankberg tellurium product is saleable.

### **3.36 Others**

There are no known potential impediments to mining other than what has been described already. All the details prompted in this section have been dealt with earlier in the report.

### **3.37 Classification**

As discussed in Section 3.33, a sample spacing of at least 60x60 meters is required for Inferred, 20x20 meters is required for Indicated and 10x10 is required for Measured.

Indicated Mineral Resources are transferred to Probable Mineral Reserves and Measured Mineral Resources are transferred to Proved Mineral Reserves, in each case by the application of a mining plan, which includes a cut-off of 525 SEK/t. However material below 525 SEK/t can be included, provided this has previously been classified as Mineral Resources and also that the mining rooms created are above an average grade of 525 SEK/t (see Section 3.29, for an explanation of Mineral Resources criteria).

When a level is planned to be included in the LoMP, any Mineral Resources that are excluded from the LoMP are dropped from the reported Mineral Resources. This is because once a level is mined and backfilled, these volumes would no longer be accessible for economic extraction. However, if there is later re-planning of this level before mining, it is possible that these excluded Mineral Resources could be re-incorporated into the LoMP and therefore the Mineral Reserves, if these satisfy the requirements outlined above. For example, if the drilling required to upgrade from Indicated to Measured or Probable to Proved increases the grade in a location that can only be mined by including peripheral material that had formerly been dropped from Mineral Resources, and the resulting room averages above 525 SEK/t, then this excluded material would be brought back into the Mineral Reserves. Another reason for this change may be a lowering of the NSR cut-off due to changes in technical or economic assumptions.

In this transfer from Mineral Resources to Mineral Reserves, pillars are omitted or designed out of the Mineral Reserves, which entails a reduction in volume and therefore tonnage by around 10%. However, as indicated in Section 3.33, 'Mineral Resource estimate for conversion to Mineral Reserves', the assumed mining recovery is increased by 10 percentage points.

All other modifying factors to transfer Mineral Resources to Mineral Reserves have already been considered elsewhere in this report. There are no Probable Mineral Reserves which have been derived from Measured Mineral Resources.

### **3.38 Audits or reviews**

In the opinion of the independent reviewer, Mr. M Howson, (2019 CPR), the system of allowance for dilution and recovery in the Mineral Resources figures may be unconventional with respect to other operations reporting under CRIRSCO standards. However, this system for Kankberg was set up historically and works well for this mine. It is not considered to be appropriate to change this system at this stage in the mine's life, but rather to explain it clearly in the CP Report.

The current system of conversion from Mineral Resources to Mineral Reserves matches the present mining method. Justification to change the mining method could be to increase mining recovery by reducing material left in pillars, to increase production rates and / or lower unit mining costs. Such a change would require a new Feasibility Study with an associated revision of the Mineral Resources and Mineral Reserves. There is no justification to change the current system at present.

### **3.39 Discussion of relative accuracy/ confidence**

There has been no application of conditional simulation to production increments to try to test the relative accuracy and confidence of the estimates. The geological staff understand this approach, but since the mine has been in production for several years with reporting under the previous FRB system, the results from reconciliation are considered to provide a more appropriate test of accuracy. This is for production increments of quarter-years, each of which include ore from several locations around the mine.

Virtually all of the ore that is mined at Kankberg is from Proved Mineral Reserves that were transferred by mine planning from Measured Mineral Resources. In Section 3.3, 'History', reconciliation shows these estimates to predict the production that is recorded at the mill in an unbiased manner and within a reasonable confidence range. It appears that Measured Mineral Resources are known with a relative accuracy of around  $\pm 20\%$  at 90% confidence for quarterly production increments (years 2015 to 2019). Therefore, the 10x10 metres drill spacing that is generally required for Measured Mineral Resources, the mine planning that transfers to Proved Mineral Reserves and the control of mining that delivers the ore are considered to be adequate.

Estimation stages of Inferred and Indicated Mineral Resources and Probable Mineral Reserves cannot be directly tested by reconciliation. To do so would not only require a different model estimation with omission of some drillholes, but also mine planning on the basis of that less perfect model. But in any case, this would not yield useful information.

Indicated Mineral Resources are a 'staging post' between Inferred and Measured, marking the point at which exploration, sampling and testing are considered sufficient to assume geological and grade continuity between points of observation, such that confidence in estimation is sufficient to support preliminary mine planning, which will be changed when more drilling has allowed estimates to be upgraded. The drilling grid for Indicated Mineral Resources of 20x20 metres involves a quarter of the number of drillholes that is required for

Measured, and this ratio is typical in the industry. An exercise to try to test the accuracy or to 'optimize' the spacing for Indicated is not considered worthwhile.

The drilling grid for Inferred Mineral Resources of 60x60 metres also seems rational as providing geological evidence that is sufficient to imply but not verify geological and grade continuity. At this spacing most parts of the mineralized zones (see the end of Section 3.7, 'Geology') would be identifiable with grades that would be sufficiently representative to allow prioritization of infill drilling for upgrading to the Indicated category. Therefore, this spacing is considered to be adequate.

### 3.40 Schematic description of the principles for reporting of Mineral Resource and Mineral Reserve

Figure 24 below provides a schematic illustration of the principles for reporting of Mineral Resource and Mineral Reserve at Kankberg mine.

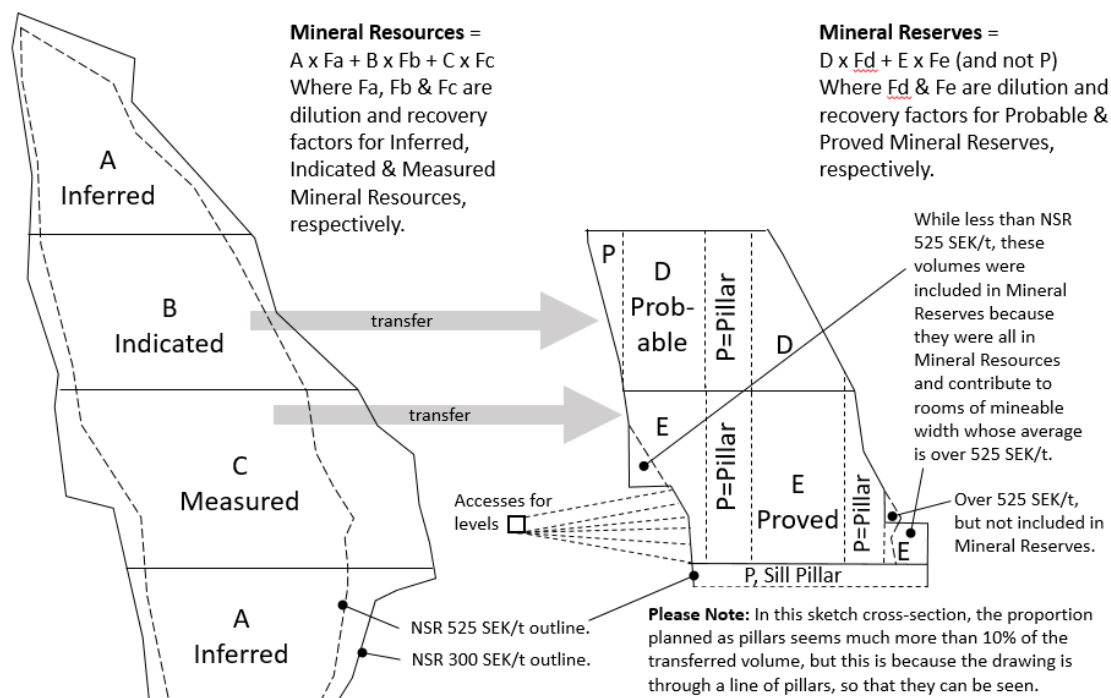

Figure 24: Schematic description of the principles for reporting of Mineral Resource and Mineral Reserve at Kankberg

The above sketch on the left side shows Mineral Resource volumes defined by an NSR 300 SEK/t cut-off. Mine planning transfers much of the Indicated and Measured categories to Mineral Reserve volumes (and pillars) shown on the right. These are defined mainly by an NSR 525 SEK/t cut-off, which is shown on the left side as a dashed line. However, on the right the Mineral Reserves also include rooms that were not entirely above NSR 525 SEK/t, but which were previously classified as Mineral Resources, are of mineable width and which average over NSR 525 SEK/t.

After LoMP planning, there may be small quantities of Mineral Resources with grade above 525 SEK/t on the same level that cannot be included in rooms to be mined. This is generally because to access these would require inclusion of low-grade material such that the average NSR value of the room would be less than 525 SEK/t. Such material is illustrated in the sketch above as 'Over 525 SEK/t, but not included in Mineral Reserves.' This would not be transferred into Mineral Reserves and it would cease to be included in Mineral Resources. However, if there were to be a revision of the LoMP, for example due to drilling required to



upgrade from Indicated to Measured Mineral Resources, and by transference from Probable to Proved Mineral Reserves, then it is possible that this material could be re-included if the requirements for Mineral Reserves become satisfied.

Section 3.33, 'Mineral Resource estimate for conversion to Mineral Reserves', Table 20 gives dilution and recovery factors as percentages, which differ for the Mineral Resources and Mineral Reserve categories shown as A to E in the sketch above. Using values from the block 'Model' aggregated into mine planning volumes, these factors are applied as follows:

Mineral Resources that cannot be transferred to Mineral Reserves:

- A, Inferred, RESCAT 5
  - Tonnes = Model Tonnes x 0.70 x (1+0.2)
  - Au Grade = Model Au Grade / (1+0.2)

Mineral Resources that could be, but have not yet been transferred to Mineral Reserves:

- B, Indicated, RESCAT 4
  - Tonnes = Model Tonnes x 0.75 x (1+0.15)
  - Au Grade = Model Au Grade / (1+0.15)
- C, Measured, RESCAT 3
  - Tonnes = Model Tonnes x 0.90 x (1+0.035)
  - Au Grade = Model Au Grade / (1+0.035)

Mineral Reserves that mine planning has transferred from Mineral Resources:

- D, Probable, RESCAT 2
  - Tonnes = Model Tonnes (excluding pillars) x 0.85 x (1+0.15)
  - Au Grade = Model Au Grade (excluding pillars) / (1+0.15)
- E, Proved, RESCAT 1
  - Tonnes = Model Tonnes (excluding pillars)
  - Au Grade = Model Au Grade (excluding pillars) / (1+0.035)

#### **4 COMPETENT PERSON'S CONSENT STATEMENTS**

Pursuant to the requirements of paragraph 3.2 of the PERC Standard.

##### **Gunnar Agmalm**

The information in the report to which this statement is attached, relates to Exploration Results, Mineral Resources and Mineral Reserves of the Kankberg Mine. This is based on information compiled by Gunnar Agmalm, who is a professional member of the Australian Institute of Mining and Metallurgy (AusIMM, membership number 227254) and Fennoscandian Association for Metals and Minerals Professionals (FAMMP, membership number 16). Mr. Agmalm is a full-time employee of Boliden Mineral AB.

Mr. Agmalm has sufficient experience which is relevant to the style of mineralisation and type of deposit under consideration and to the activity which he is undertaking to qualify as a Competent Person as defined in the 2017 Edition of the 'PERC Standard for Reporting of Exploration Results, Mineral Resources and Reserves'. Mr. Agmalm consents to the inclusion in the report of the matters based on his information in the form and context in which it appears.

Signed:

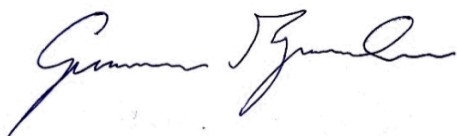

Gunnar Agmalm, 31-12-2020

##### **Johan Bradley**

The information in the report to which this statement is attached, relates to Exploration Results, Mineral Resources and Mineral Reserves of the Kankberg Mine. This is based on information compiled by Johan Bradley, who is a professional Fellow (membership number 1014008) with 'Chartered' Status of the Geological Society of London and European Geologist Status with the European Federation of Geologists. Mr. Bradley is a full-time employee of Boliden Mineral AB.

Mr Bradley has sufficient experience which is relevant to the style of mineralisation and type of deposit under consideration and to the activity which he is undertaking to qualify as a Competent Person as defined in the 2017 Edition of the 'PERC Standard for Reporting of Exploration Results, Mineral Resources and Reserves'. Mr Bradley consents to the inclusion in the report of the matters based on his information in the form and context in which it appears.

Signed:



Johan Bradley, 31-12-2020

**Seth Mueller**

The information in the report to which this statement is attached, relates to Exploration Results, Mineral Resources and Mineral Reserves of the Kankberg Mine. This is based on information compiled by Seth Mueller, who is a professional member of the Fennoscandian Association for Metals and Minerals Professionals (FAMMP, membership number 36). Mr. Mueller is a full-time employee of Boliden Mineral AB.

Mr. Mueller has sufficient experience which is relevant to permitting and environmental procedures associated with this mineralisation and type of deposit under consideration and to the activity which he is undertaking to qualify as a Competent Person as defined in the 2017 Edition of the 'PERC Standard for Reporting of Exploration Results, Mineral Resources and Reserves'. Mr. Mueller consents to the inclusion in the report of the matters based on his information in the form and context in which it appears.

Signed:



Seth Mueller, 31-12-2020

**Anders Sand**

The information in the report to which this statement is attached, relates to Exploration Results, Mineral Resources and Mineral Reserves of the Kankberg Mine. This is based on information compiled by Anders Sand, who is a professional member of the Fennoscandian Association for Metals and Minerals Professionals (FAMMP, membership number 38). Dr. Sand is a full-time employee of Boliden Mineral AB.

Dr. Sand has sufficient experience which is relevant to the style of mineralisation and type of deposit under consideration and to the activity which he is undertaking to qualify as a Competent Person as defined in the 2017 Edition of the 'PERC Standard for Reporting of Exploration Results, Mineral Resources and Reserves'. Dr. Sand consents to the inclusion in the report of the matters based on his information in the form and context in which it appears.

Signed:

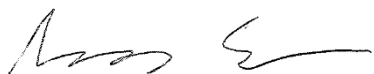

Anders Sand, 31-12-2020

## 5 REFERENCES

### 5.1 External references

Allen, R.L., Weihed, P., Svensson, S-Å. (1996): Setting of Zn-Cu-Au-Ag massive sulphide deposits in the evolution and facies architecture of a 1.9 Ga marine volcanic arc, Skellefte district, Sweden. *Economic Geology* 91, p.1022-1053.

Kathol, B., Weihed, P (eds.). (2005): Description of regional geological and geophysical maps of the Skellefte District and surrounding areas, ISBN 91-7158-678-4, SGU: Ba 57

Pan-European Standard for reporting of Exploration results, Mineral Resources and Mineral Reserves (The PERC Reporting standard 2017.) [www.percstandard.eu](http://www.percstandard.eu)

Parker, H. (2010) “Quantitative Criteria for Mineral Resource Classification” (presentation) GRZ – CRIRSCO Seminar on Russian and International Mineral Resources / Reserves Reporting Standards – Moscow, 27 September 2010.

Sinclair, A. J. & Blackwell, G. H., (2002), Applied Mineral Inventory Estimation, Cambridge University Press, ISBN 0-521-79103-0

### 5.2 Internal references

For access to internal references contact author or the Head of Department of relevance.

Agmalm, G. (2011): Kankberg, Åkulla Östra mineralization Feasibility Study. Boliden DMS#: 474882.

Bohlin, N.-J. (2010): Mineralogical study of ore samples from Åkulla Östra. Boliden, TM\_REP2009/037.

Baldwin, S. (2018): Kankberg campaign Reconciliation DV\_MEMO 2018/01, Boliden DMS #11900535.

Fahlgren, J. (2015a): A lithochemical review of the Kankberg Au-Te deposit, Boliden Area. Boliden, GP2015-25.

Fahlgren, J. (2015b): GeoGuide\_Kankberg\_AuTe\_Geology\_JF\_20150415.

Lundberg M. (2018): Mineral processing, Pers. Comm. 2018.

Lundh, J., Holmen-Fröberg, S., Nordfeldt, P., Munck, M., & Wasström, A. (2016): Kankberg/Åkulla Östra Au-Mineralisation: Exploration Report, 2015 to 1Q2016. Boliden, GP 2016-20.

Munck, N. (2017): U QA\_QC Guideline and work flow (C20556).

Voigt, B. (2017): Kankberg/Östra Åkulla Au-mine, Mineral Reserves and Resources as of 2017-12-31, Boliden Mineral Reserves and Resources Report 2017, DMS# 1160696.

Voigt, B. (2018): Reserves and Resources G1N 2018-12-31, Boliden Mineral Reserves and Resources Report 2018 (Excel), DMS# 1307888.

Voigt, B., Howson, M. & Bradley, J. (2019): Kankberg – Åkulla Östra Au mine, Mineral Resources and Reserves as of 2019-12-31, Boliden Mineral Resources and Reserves Report 2019, DMS# 1589509.

Wasström, A. (1997): Au-mineraliseringen i Åkulla Östra. Boliden, GP97003.

Wasström, A., Agmalm, G., & Nilsson, P. (1999): Exploration Report- Status Report 1999 Åkulla Östra Mine Investigation- Geology. Boliden, GP 99 021.

Wasström, A., Agmalm, G., & Sandström, B. (2009): Åkulla Östra Au-mineralisation and resource estimation 2007-2009. Boliden, GP 2009-47.

Žižek, T. (2018): Mining methods, Pers. Comm. 2018.

Åberg, L. (2019): Mineral Resource estimate for Kankberg, Boliden Ore Reserves Report 2019.

## Appendix 1

### A Brief Pre-Production History of the Kankberg Underground Mine

1927	Exploration started in the Åkulla area.
1928 - 1933	Electrical ground measurements. At Åkulla Östra Cu-Au-Zn mineralization was found in 4 drill cores.
1938	A drift is made from Åkulla Västra under this mineralization. A Cu-Au mineralization associated with quartz-filled cracks was discovered at a depth of 130 m.
1939	Åkulla Östra consists of several small sulphide lenses. The drift was filled with water.
1943 - 1952	Geological exploration and geophysical ground measurements.
1967 - 1969	Drilling and planning for open pit.
1984	Some drill holes drilled in the “Deep-seated sulphide ore” project. No new mineralized bodies were found.
1991	A new exploration campaign with geophysical ground measurements and geological surveying.
1994	Detailed geological outcrop logging and a new drilling campaign. The first drill hole intersected a new 10 m wide massive pyrite lens at a depth of 260 m in December. The grades were ‘too low’ but the drilling campaign continued due to geological and geophysical interpretations indicating mineralization at a deeper level.
1995	On 1 March a new type of Au mineralization was found in a strong Si-Al alteration zone at a depth of 350 m. This alteration zone had mineable thicknesses with high Au contents, and is characteristic of the present Kankberg orebody.
1996	First metallurgical tests on sample material from drill cores.
1997 - 1998	Åkulla Östra B lens is mined in open pit.
1997	Ramp commenced towards Åkulla Östra Au mineralization.
1998 - 1999	Exploration within the Åkulla Östra Mine commenced. 20 drill holes.
1998	Processing tests on 1 350 t from the ramp.
2004 - 2006	Åkulla Östra Mine exploration continued. Exploration department drilled 86 drill holes of which 3 were extensions of existing drill holes.
2006	Test mining and a pilot processing test on 11 100 t. Some material from the 1999 ramp was used to clean the line.
2007	A drilling programme of 27 drill holes was initiated, of which one was an extension of an existing drill hole.
2008	The drilling programme was concluded. Conceptual study on extraction of tellurides shows good potential for profitability. Analyses campaign on tellurides.
2009 - 2010	A new ramp is started and a new drilling campaign is completed.
2011 -	The Feasibility Study (FS) is completed in January. Infill drilling programme commences.
2012	Production at Kankberg begins in January.

## Appendix 2

### Explanation of the Mine Local Grid, G1NSYSTEMET

Origin of the mine's local grid has the following coordinates:		
Origin	National grid	
	SWEREF99 TM RH 70	(RT90 2.5 g V 0: -15) (RH00)
<b>X</b>	7 212 526.158	(RT90: 7 211 886.192)
<b>Y</b>	746 115.962	(RT90: 1 708 251.873)
<b>Z</b>	280.78	(RH00: 280.000)
Angle from the mine grid's north to the national grid's north is:	290.510 degrees	(289.779 degrees)
E: E-value	285.785 degrees	(285.783 degrees)
MKV: Convergence of meridian	4.725 degrees	(3.996 degrees)
D: Declination	ca 7.5 degrees	
GN: Geographical north		
MN: Magnetic north		
RIKET: SWEREF99 TM		
GRUVAN: Kankberg mine		
All angles are positive clockwise		

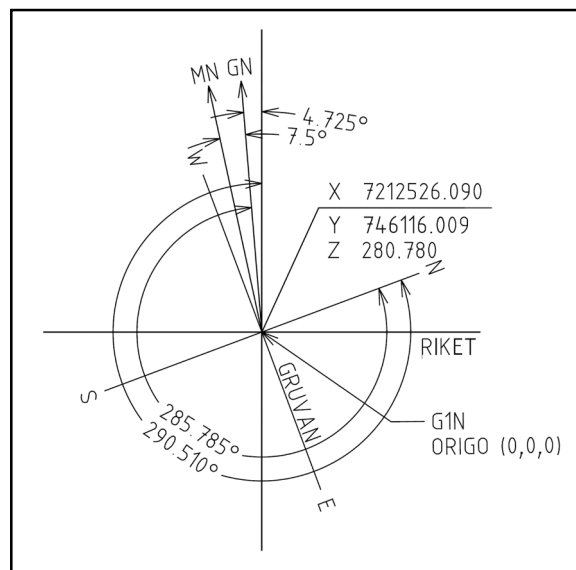

The relationship between the coordinate systems has been established by surveying of fixed local points (Swedish: stompunkter) above ground using GNSS (Global Navigation Satellite System) and a network of permanent reference stations (Nätverks-RTK) in 2010 in the RT90 2.5 gon V 0:-15 system. This relationship was then transformed into the SWEREF99 TM system.

E-value is the angle between geographical north the positive X-axis of the mine grid (G1N systemet).

Convergence of the meridian is the angle between geographical north and the positive X-axis of the national grid

Declination is the angle between geographical north and magnetic north





**Kankbergsgruvan**  
**Rum N514 s6**  
**Skala: 1:500 (A4)**  
**Utskriftsdatum:**  
**2019-11-27**

Rum N514 skiva 6  
 Plan tak 515.0 m  
 Fyllsuta 522.0 m  
 Tunneln ligger 7 m  
 under planerat tak,  
 dvs 2 322.0 m.

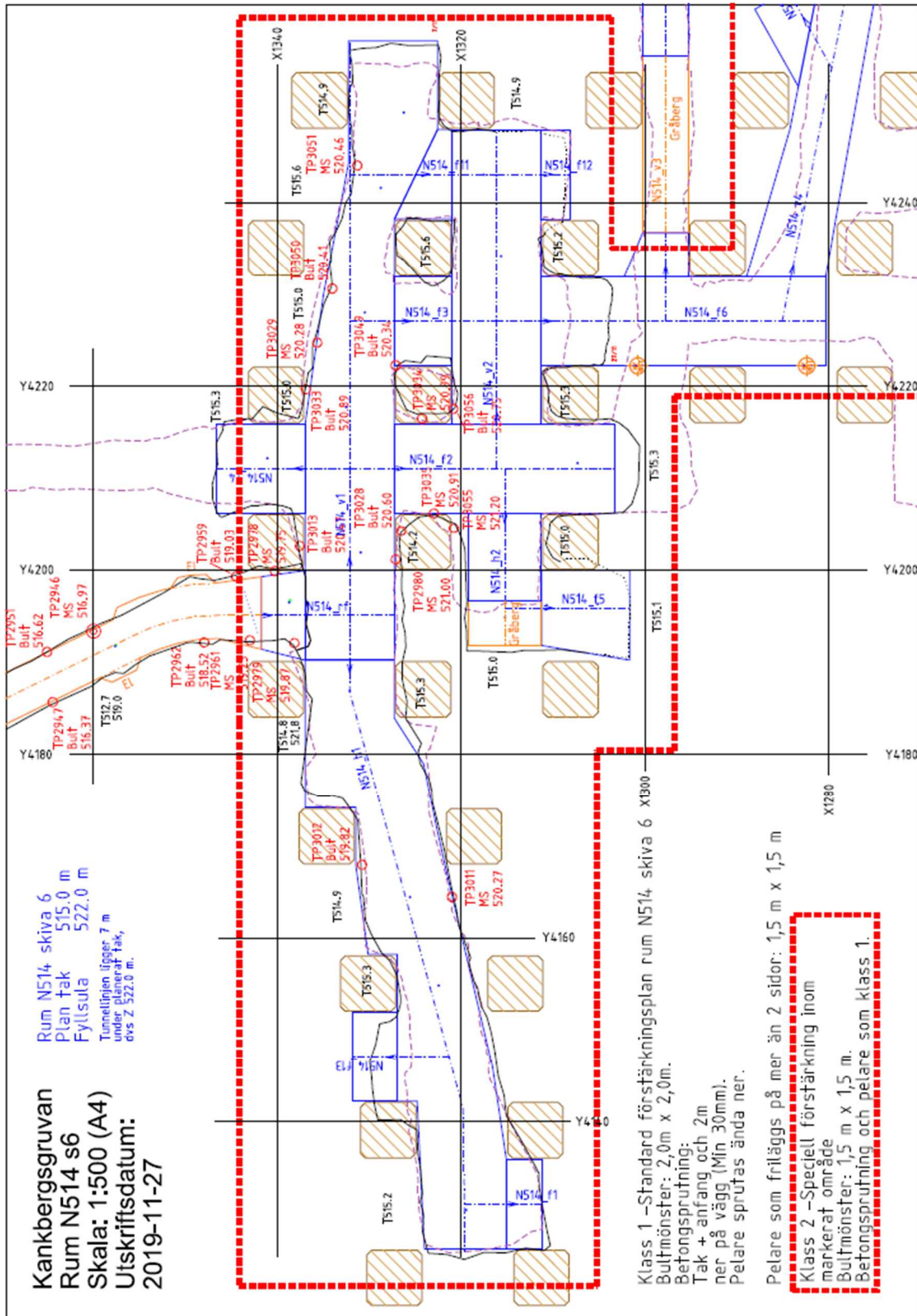

Klass 1 –Standard förstärkningsplan rum N514 skiva 6 xB00  
 Bultmönster: 2,0m x 2,0m.

Betongsprutning:  
 Tak + anfang och 2m  
 ner på vägg (Min 30mm).  
 Pelare sprutas ända ner.

Pelare som friläggs på mer än 2 sidor: 1,5 m x 1,5 m

Klass 2 –Speciell förstärkning inom  
 markerat område  
 Bultmönster: 1,5 m x 1,5 m.  
 Betongsprutning och pelare som klass 1.

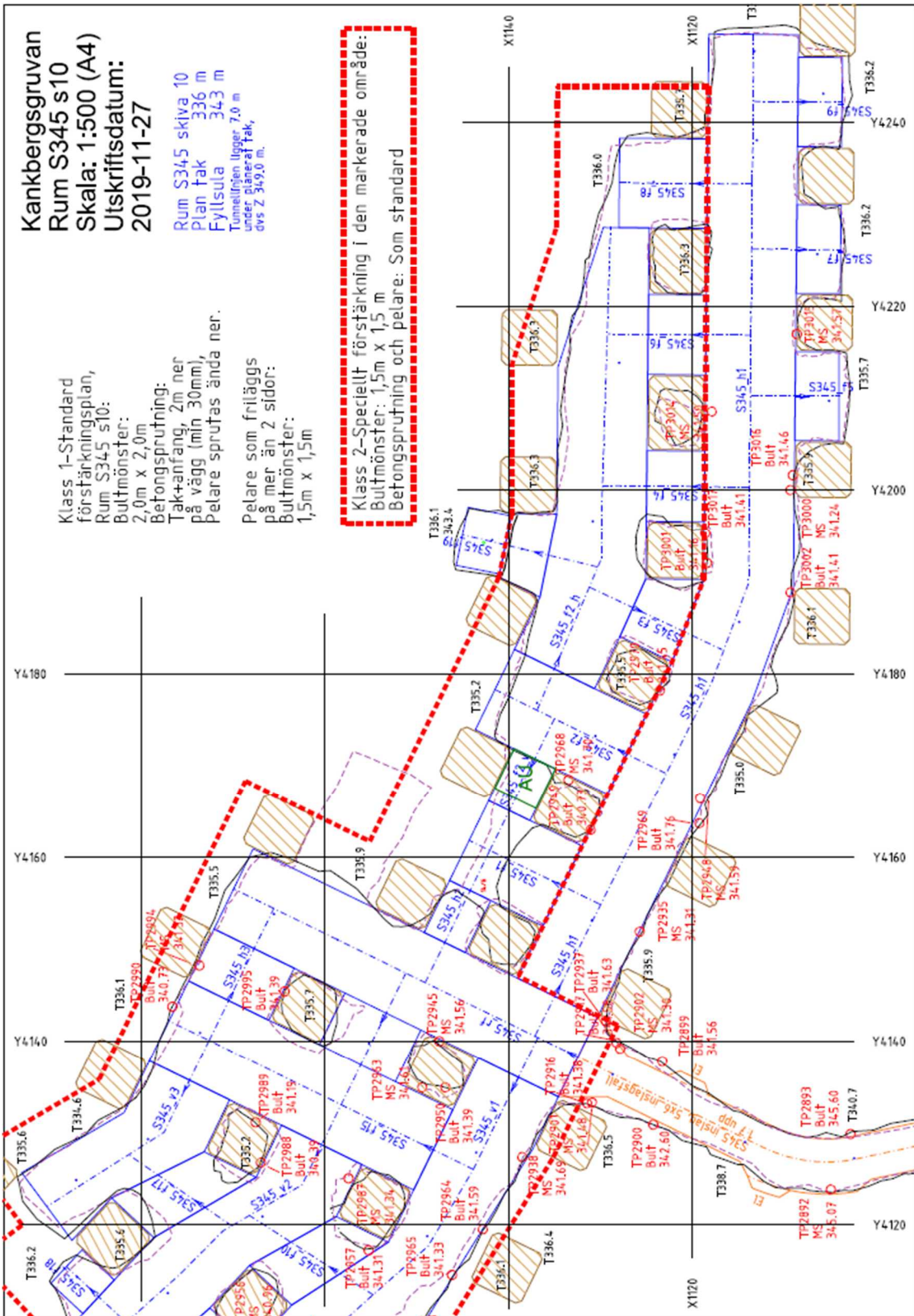

## Appendix 4

Examples of Plans and Profiles showing drillholes and block model NSR grades (images from 2019).

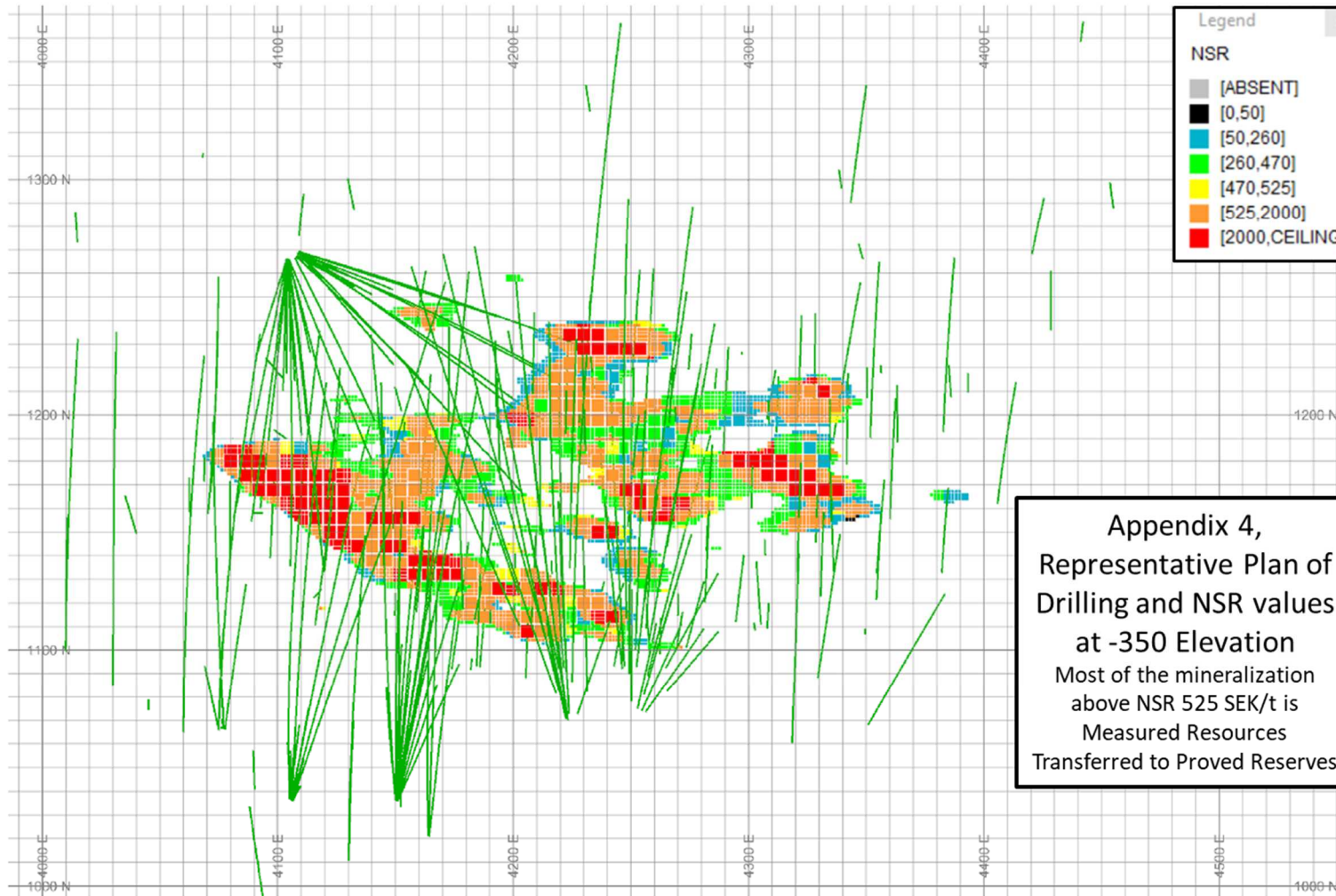

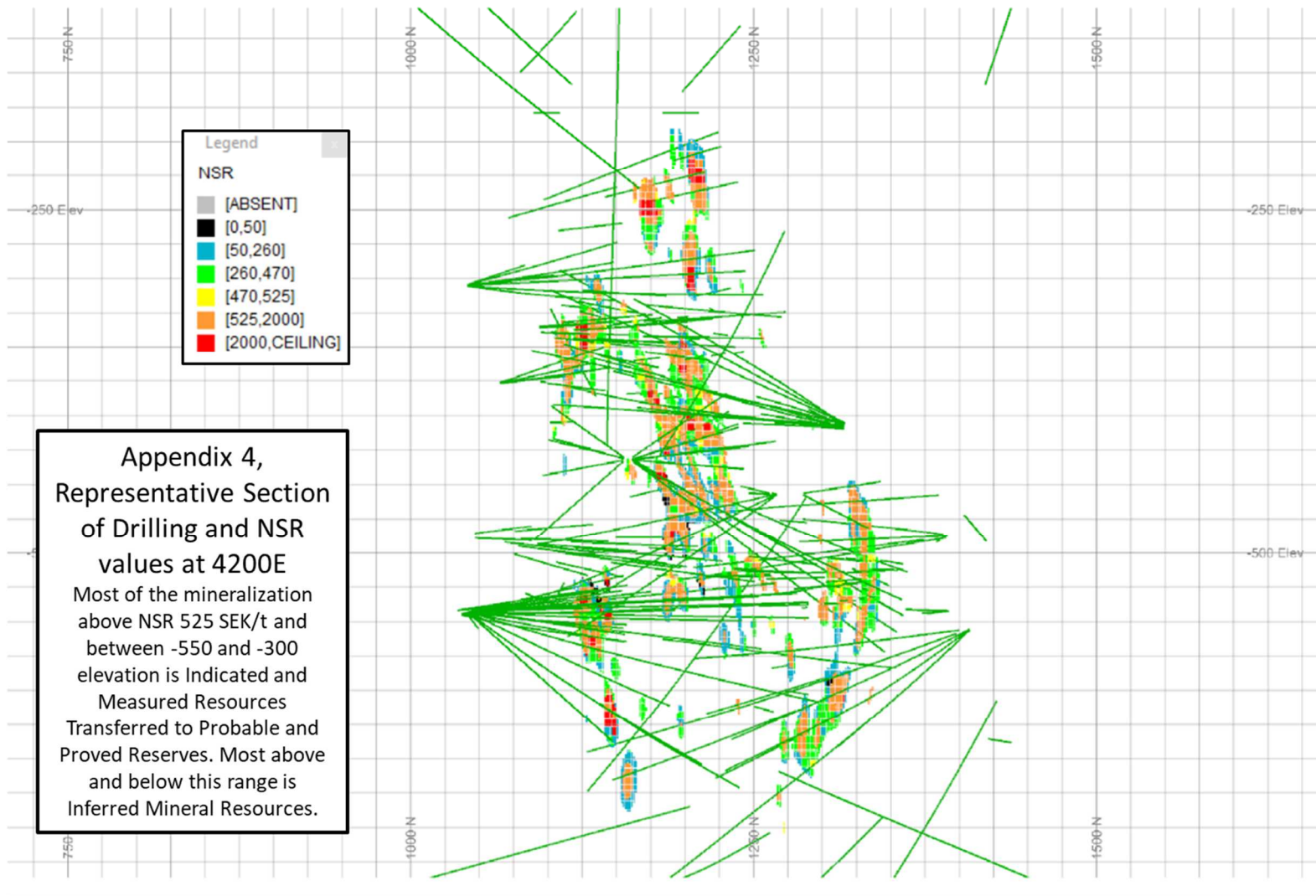

## Appendix 5

3D view of Mineral Reserves and Mineral Resources classification and existing infrastructure (images from 2019).

